



An Oshkosh Corporation Company

---

# ***Operation and Safety Manual***

*Original Instructions - Keep this manual with the machine at all times.*

**Model**  
**260MRT**



**P/N - 3121219**  
*June 5, 2012*



## **FOREWORD**

This manual is a very important tool! Keep it with the machine at all times.

The purpose of this manual is to provide owners, users, operators, lessors, and lessees with the precautions and operating procedures essential for the safe and proper machine operation for its intended purpose.

Due to continuous product improvements, JLG Industries, Inc. reserves the right to make specification changes without prior notification. Contact JLG Industries, Inc. for updated information.

## SAFETY ALERT SYMBOLS AND SAFETY SIGNAL WORDS



This is the Safety Alert Symbol. It is used to alert you to the potential personal injury hazards. Obey all safety messages that follow this symbol to avoid possible injury or death

### **DANGER**

INDICATES AN IMMINENTLY HAZARDOUS SITUATION. IF NOT AVOIDED, WILL RESULT IN SERIOUS INJURY OR DEATH. THIS DECAL WILL HAVE A RED BACKGROUND.

### **WARNING**

INDICATES A POTENTIALITY HAZARDOUS SITUATION. IF NOT AVOIDED, COULD RESULT IN SERIOUS INJURY OR DEATH. THIS DECAL WILL HAVE AN ORANGE BACKGROUND.

### **CAUTION**

INDICATES A POTENTIALITY HAZARDOUS SITUATION. IF NOT AVOIDED, MAY RESULT IN MINOR OR MODERATE INJURY. IT MAY ALSO ALERT AGAINST UNSAFE PRACTICES. THIS DECAL WILL HAVE A YELLOW BACKGROUND.

### **NOTICE**

INDICATES INFORMATION OR A COMPANY POLICY THAT RELATES DIRECTLY OR INDIRECTLY TO THE SAFETY OF PERSONNEL OR PROTECTION OF PROPERTY.

**⚠ WARNING**

THIS PRODUCT MUST COMPLY WITH ALL SAFETY RELATED BULLETINS. CONTACT JLG INDUSTRIES, INC. OR THE LOCAL AUTHORIZED JLG REPRESENTATIVE FOR INFORMATION REGARDING SAFETY-RELATED BULLETINS WHICH MAY HAVE BEEN ISSUED FOR THIS PRODUCT.

**NOTICE**

JLG INDUSTRIES, INC. SENDS SAFETY RELATED BULLETINS TO THE OWNER OF RECORD OF THIS MACHINE. CONTACT JLG INDUSTRIES, INC. TO ENSURE THAT THE CURRENT OWNER RECORDS ARE UPDATED AND ACCURATE.

**NOTICE**

JLG INDUSTRIES, INC. MUST BE NOTIFIED IMMEDIATELY IN ALL INSTANCES WHERE JLG PRODUCTS HAVE BEEN INVOLVED IN AN ACCIDENT INVOLVING BODILY INJURY OR DEATH OF PERSONNEL OR WHEN SUBSTANTIAL DAMAGE HAS OCCURRED TO PERSONAL PROPERTY OR THE JLG PRODUCT.

**For:**

- Accident Reporting
- Product Safety Publications
- Current Owner Updates
- Questions Regarding Product Safety
- Standards and Regulations Compliance Information
- Questions Regarding Special Product Applications
- Questions Regarding Product Modifications

**Contact:**

Product Safety and Reliability Department  
JLG Industries, Inc.  
1 JLG Drive  
McConnellsburg, PA 17233

or Your Local JLG Office  
(See addresses on inside of manual cover)

**In USA:**

Toll Free: 877-JLG-SAFE (877-554-7233)

**Outside USA:**

Phone: 717-485-5161  
E-mail: ProductSafety@JLG.com

## **REVISION LOG**

Original Issue	- June 27, 2005
Revised	- July 17, 2006
Revised	- March 29, 2007
Revised	- October 22, 2008
Revised	- April 15, 2010
Revised	- May 14, 2010
Revised	- June 5, 2012

<b>SECTION - PARAGRAPH, SUBJECT</b>	<b>PAGE</b>
<b>SECTION - 1 - SAFETY PRECAUTIONS</b>	
1.1 GENERAL . . . . .	1-1
1.2 PRE-OPERATION . . . . .	1-1
Operator Training and Knowledge . . . . .	1-1
Workplace Inspection . . . . .	1-2
Machine Inspection . . . . .	1-4
1.3 OPERATION . . . . .	1-4
General . . . . .	1-4
Trip and Fall Hazards . . . . .	1-5
Electrocution Hazards . . . . .	1-6
Tipping Hazards . . . . .	1-8
Crushing and Collision Hazards . . . . .	1-9
1.4 TOWING, LIFTING, AND HAULING . . . . .	1-10
1.5 MAINTENANCE . . . . .	1-10
General . . . . .	1-10
Maintenance Hazards . . . . .	1-10
Battery Hazards . . . . .	1-11
<b>SECTION - 2 - USER RESPONSIBILITIES, MACHINE PREPARATION AND INSPECTION</b>	
2.1 PERSONNEL TRAINING . . . . .	2-1
Operator Training . . . . .	2-1
Training Supervision . . . . .	2-1
Operator Responsibility . . . . .	2-1
2.2 PREPARATION, INSPECTION, AND	

<b>SECTION - PARAGRAPH, SUBJECT</b>	<b>PAGE</b>
MAINTENANCE . . . . .	2-2
2.3 PRE-START INSPECTION . . . . .	2-4
Preparing the Machine for Operation . . . . .	2-5
Function Check . . . . .	2-5
2.4 DUAL FUEL SYSTEM (IF EQUIPPED) . . . . .	2-7
GENERAL . . . . .	2-9
<b>SECTION - 3 - USER RESPONSIBILITIES AND MACHINE CONTROL</b>	
3.1 GENERAL . . . . .	3-1
3.2 OPERATING CHARACTERISTICS AND LIMITATIONS . . . . .	3-1
General . . . . .	3-1
Placards . . . . .	3-1
Capacities . . . . .	3-1
3.3 CONTROLS AND INDICATORS . . . . .	3-2
Ground Control Station . . . . .	3-2
3.4 PLATFORM CONTROL STATION . . . . .	3-8
Platform Control Front Panel . . . . .	3-9
Indicator Panel LED's . . . . .	3-10
<b>SECTION - 4 - MACHINE OPERATION</b>	
4.1 DESCRIPTION . . . . .	4-1
4.2 ENGINE OPERATION . . . . .	4-1
Power Selector Switch . . . . .	4-1

## TABLE OF CONTENTS

SECTION - PARAGRAPH, SUBJECT	PAGE	SECTION - PARAGRAPH, SUBJECT	PAGE
Emergency Stop Switch . . . . .	4-1	Operator Unable to Control Machine . . . . .	5-2
Starting Procedure . . . . .	4-1	Platform Caught Overhead . . . . .	5-2
4.3 OPERATING CHARACTERISTICS . . . . .	4-3	Righting of Tipped Machine . . . . .	5-2
Leveling Jacks . . . . .	4-3	Post-Incident Inspection . . . . .	5-2
Auto Leveling . . . . .	4-3	5.3 INCIDENT NOTIFICATION . . . . .	5-3
Manual Level Adjustment (Trim) . . . . .	4-4		
4.4 PLATFORM . . . . .	4-4	<b>SECTION - 6 - GENERAL SPECIFICATIONS AND OPERATOR MAINTENANCE</b>	
Raising . . . . .	4-4	6.1 INTRODUCTION . . . . .	6-1
Lowering . . . . .	4-5	6.2 OPERATING SPECIFICATIONS . . . . .	6-2
Platform Extension . . . . .	4-5	Dimensional Data . . . . .	6-3
4.5 DRIVING . . . . .	4-6	Capacities . . . . .	6-3
Steering . . . . .	4-6	Engine . . . . .	6-4
Driving Forward . . . . .	4-6	Lubrication . . . . .	6-7
Driving in Reverse . . . . .	4-6	6.3 OPERATOR MAINTENANCE . . . . .	6-8
4.6 PARKING AND STOWING . . . . .	4-8	6.4 TIRES AND WHEELS . . . . .	6-10
4.7 PLATFORM LOADING . . . . .	4-8	Tire Damage . . . . .	6-10
4.8 SAFETY PROP . . . . .	4-8	Tire Replacement . . . . .	6-10
4.9 TIE DOWN . . . . .	4-9	Wheel Replacement . . . . .	6-11
Lifting . . . . .	4-9	Wheel Installation . . . . .	6-11
4.10 TOWING . . . . .	4-9	6.5 SUPPLEMENTAL INFORMATION . . . . .	6-12
<b>SECTION - 5 - EMERGENCY PROCEDURES</b>		<b>SECTION - 7 - INSPECTION AND REPAIR LOG</b>	
5.1 GENERAL . . . . .	5-1		
Emergency Stop Switch . . . . .	5-1		
Manual Descent . . . . .	5-1		
5.2 EMERGENCY OPERATION . . . . .	5-1		



<b>SECTION - PARAGRAPH, SUBJECT</b>	<b>PAGE</b>
<b>LIST OF FIGURES</b>	
2-1. Walk Around Inspection Diagram . . . . .	2-8
2-2. Walk Around Inspection Points - Sheet 1 . . . . .	2-9
2-3. Walk Around Inspection Points - Sheet 2 . . . . .	2-10
3-1. Ground Control Station . . . . .	3-4
3-2. Platform Control Station . . . . .	3-5
3-3. Indicator Panel . . . . .	3-6
3-4. Platform Control Front Panel . . . . .	3-7
3-5. Decal Location (ANSI) . . . . .	3-12
3-6. Decal Location (ANSI Export) . . . . .	3-14
3-7. Decal Location (CE/AUS) . . . . .	3-16
4-1. Grade and Sideslope Depiction . . . . .	4-7
4-2. Lifting Chart . . . . .	4-11
6-1. Engine Operating Temperature Specifications (Kubota)- Sheet 1 of 2 . . . . .	6-5
6-2. Engine Operating Temperature Specifications (Kubota)- Sheet 2 of 2 . . . . .	6-6
6-3. Lubrication Diagram . . . . .	6-8

<b>SECTION - PARAGRAPH, SUBJECT</b>	<b>PAGE</b>
<b>LIST OF TABLES</b>	
Beaufort Scale (For Reference Only) . . . . .	1-3
Minimum Approach Distances (M.A.D.) . . . . .	1-7
Inspection and Maintenance Table . . . . .	2-3
Tilt Sensor Preset Configuration . . . . .	2-6
Decal Legend (ANSI) . . . . .	3-13
Decal Legend (ANSI Export) . . . . .	3-15
Decal Legend - (CE/AUS) . . . . .	3-17
Operating Specifications . . . . .	6-2
Dimensional Data . . . . .	6-3
Capacities . . . . .	6-3
Tire Specifications . . . . .	6-3
Engine Specifications . . . . .	6-4
Engine Battery Specifications . . . . .	6-4
Hydraulic Oil . . . . .	6-7
Lubrication Specifications . . . . .	6-7
Inspection and Repair Log . . . . .	7-1

## **TABLE OF CONTENTS**

---

**SECTION - PARAGRAPH, SUBJECT**

**PAGE**

**SECTION - PARAGRAPH, SUBJECT**

**PAGE**

**This page intentionally left blank.**

## SECTION 1. SAFETY PRECAUTIONS

### 1.1 GENERAL

This section outlines the necessary precautions for proper and safe machine usage and maintenance. In order to promote proper machine usage, it is mandatory that a daily routine is established based on the content of this manual. A maintenance program, using the information provided in this manual and the Service and Maintenance Manual, must also be established by a qualified person and must be followed to ensure that the machine is safe to operate.

The owner/user/operator/lessor/lessee of the machine should not accept operating responsibility until this manual has been read, training is accomplished, and operation of the machine has been completed under the supervision of an experienced and qualified operator.

These sections contain the responsibilities of the owner, user, operator, lessor, and lessee concerning safety, training, inspection, maintenance, application, and operation. If there are any questions with regard to safety, training, inspection, maintenance, application, and operation, please contact JLG Industries, Inc. ("JLG").

### **⚠ WARNING**

**FAILURE TO COMPLY WITH THE SAFETY PRECAUTIONS LISTED IN THIS MANUAL COULD RESULT IN MACHINE DAMAGE, PROPERTY DAMAGE, PERSONAL INJURY OR DEATH.**

### 1.2 PRE-OPERATION

#### Operator Training and Knowledge

- The Operators and Safety Manual must be read in its entirety before operating the machine. For clarification, questions, or additional information regarding any portions of this manual, contact JLG Industries, Inc.

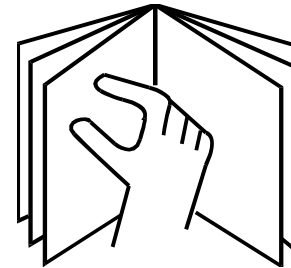

## **SECTION 1 - SAFETY PRECAUTIONS**

---

- An operator must not accept operating responsibilities until adequate training has been given by competent and authorized persons.
- Allow only those authorized and qualified personnel to operate the machine who have demonstrated that they understand the safe and proper operation and maintenance of the unit.
- Read, understand, and obey all DANGERS, WARNINGS, CAUTIONS, and operating instructions on the machine and in this manual.
- Ensure that the machine is to be used in a manner which is within the scope of its intended application as determined by JLG.
- All operating personnel must be familiar with the emergency controls and emergency operation of the machine as specified in this manual.
- Read, understand, and obey all applicable employer, local, and governmental regulations as they pertain to your utilization and application of the machine.

### **Workplace Inspection**

- Precautions to avoid all hazards in the work area must be taken by the user before operation of the machine.
- Do not operate or raise the platform from a position on trucks, trailers, railway cars, floating vessels, scaffolds or other equipment unless the application is approved in writing by JLG.
- Before operation, check work area for overhead hazards such as electric lines, bridge cranes, and other potential overhead obstructions.
- Check floor surfaces for holes, bumps, drop-offs, obstructions, debris, concealed holes, and other potential hazards.
- Check the work area for hazardous locations. Do not operate the machine in hazardous environments unless approved for that purpose by JLG.
- Ensure that the ground conditions are adequate to support the maximum tire load indicated on the tire load decals located on the chassis adjacent to each wheel.
- This machine can be operated in nominal ambient temperatures of 0° F to 104° F (-20° C to 40° C). Consult JLG to optimize operation outside of this temperature range.

**NOTICE**

**DO NOT OPERATE THE MACHINE WHEN WIND CONDITIONS EXCEED 28 MPH (12.5 M/S).**

**Table 1-1. Beaufort Scale (For Reference Only)**

Beaufort Number	Wind Speed		Description	Land Conditions
	mph	m/s		
0	0	0-0.2	Calm	Calm. Smoke rises vertically
1	1-3	0.3-1.5	Light air	Wind motion visible in smoke
2	4-7	1.6-3.3	Light breeze	Wind felt on exposed skin. Leaves rustle
3	8-12	3.4-5.4	Gentle breeze	Leaves and smaller twigs in constant motion
4	13-18	5.5-7.9	Moderate breeze	Dust and loose paper raised. Small branches begin to move.
5	19-24	8.0-10.7	Fresh breeze	Smaller trees sway.
6	25-31	10.8-13.8	Strong breeze	Large branches in motion. Whistling heard in overhead wires. Umbrella use becomes difficult.
7	32-38	13.9-17.1	Near Gale/Moderate Gale	Whole trees in motion. Effort needed to walk against the wind.
8	39-46	17.2-20.7	Fresh Gale	Twigs broken from trees. Cars veer on road.
9	47-54	20.8-24.4	Strong Gale	Light structure damage.

### Machine Inspection

- Do not operate this machine until the inspections and functional checks have been performed as specified in Section 2 of this manual.
- Do not operate this machine until it has been serviced and maintained according to the maintenance and inspection requirements as specified in the machine's Service and Maintenance Manual.
- Ensure all safety devices are operating properly. Modification of these devices is a safety violation.

### **WARNING**

#### **MODIFICATION OR ALTERATION OF AN AERIAL WORK PLATFORM SHALL BE MADE ONLY WITH PRIOR WRITTEN PERMISSION FROM THE MANUFACTURER**

- Do not operate any machine on which the safety or instruction placards or decals are missing or illegible.
- Check the machine for modifications to original components. Ensure that any modifications have been approved by JLG.
- Avoid accumulation of debris on platform deck. Keep mud, oil, grease, and other slippery substances from footwear and platform deck.

### 1.3 OPERATION

#### General

- Do not use the machine for any purpose other than positioning personnel, their tools, and equipment.
- Before operation, the user must be familiar with the machine capabilities and operating characteristics of all functions.
- Never operate a malfunctioning machine. If a malfunction occurs, shut down the machine. Remove the unit from service and notify the proper authorities.
- Do not remove, modify, or disable any safety devices.
- Never slam a control switch or lever through neutral to an opposite direction. Always return switch to neutral and stop before moving the switch to the next function. Operate controls with slow and even pressure.
- Hydraulic cylinders, other than the outrigger cylinders, should never be left at end of travel (fully extended or fully retracted) before shutdown or for long periods of time. Always “bump” control in opposite direction slightly when function reaches end of travel. This applies both to machines in operation or in the stowed position.

- Do not allow personnel to tamper with or operate the machine from the ground with personnel in the platform, except in an emergency.
- Do not carry materials directly on platform railing unless approved by JLG.
- When two or more persons are in the platform, the operator shall be responsible for all machine operations.
- Always ensure that power tools are properly stowed and never left hanging by their cord from the platform work area.
- Do not assist a stuck or disabled machine by pushing or pulling except by pulling at the chassis tie-down lugs.
- Stow scissor arm assembly and shut off all power before leaving machine.

### Trip and Fall Hazards

- JLG Industries, Inc. recommends that all persons in the platform wear a full body harness with a lanyard attached to an authorized lanyard anchorage point while operating this machine. For further information regarding fall protection requirements on JLG products, contact JLG Industries, Inc.

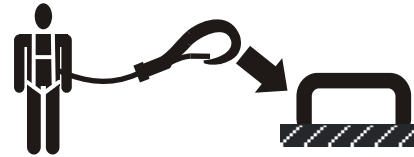

- Prior to operation, ensure all gates and rails are fastened and secured in their proper position. Identify the designated lanyard anchorage point(s) at the platform and securely attach the lanyard. Attach only one (1) lanyard per lanyard anchorage point

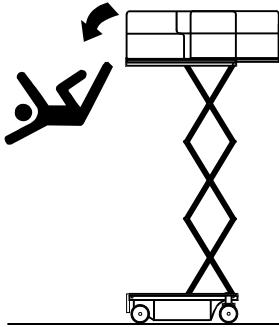

- Keep both feet firmly positioned on the platform floor at all times. Never position ladders, boxes, steps, planks, or similar items on unit to provide additional reach for any purpose.
- Never use the scissor arm assembly to gain access to or leave the platform.
- Use extreme caution when entering or leaving platform. Ensure that the scissor arm assembly is fully lowered. Face the machine when entering or leaving the platform. Always maintain “three point contact” with the machine, using two hands and one foot or two feet and one hand at all times during entry and exit.
- Keep oil, mud, and slippery substances cleaned from footwear and the platform floor.

### Electrocution Hazards

- This machine is not insulated and does not provide protection from contact or proximity to electrical current.

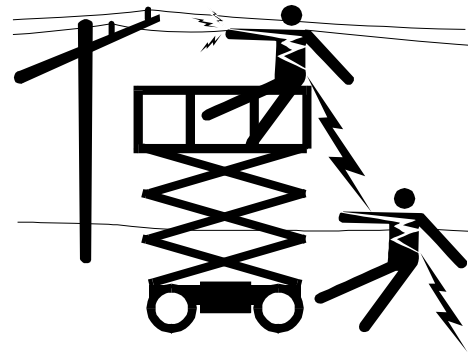
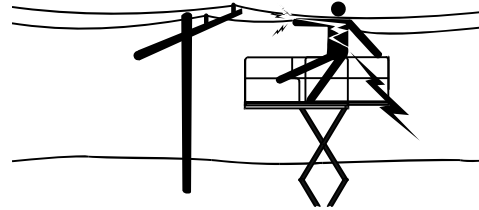



## SECTION 1 - SAFETY PRECAUTIONS

- Maintain safe clearance from electrical lines, apparatus, or any energized (exposed or insulated) parts in accordance with the Minimum Approach Distance (MAD) as specified in Table 1-1.
- Allow for machine movement and electrical line swaying.

**Table 1-2. Minimum Approach Distances (M.A.D.)**

Voltage Range (Phase to Phase)	MINIMUM APPROACH DISTANCE in Feet (Meters)
0 to 50KV	10 (3)
Over 50 kV to 200 KV	15 (5)
Over 200KV to 350 KV	20 (6)
Over 350 KV to 500 KV	25 (8)
Over 500 KV to 750 KV	35 (11)
Over 750 KV to 1000 KV	45 (14)

**NOTE:** *This requirement shall apply except where employer, local or governmental regulations are more stringent.*

- Maintain a clearance of at least 10 ft. (3m) between any part of the machine and its occupants, their tools, and their equipment from any electrical line or apparatus car-

rying up to 50,000 volts. One foot additional clearance is required for every additional 30,000 volts or less.

- The minimum approach distance may be reduced if insulating barriers are installed to prevent contact, and the barriers are rated for the voltage of the line being guarded. These barriers shall not be part of (or attached to) the machine. The minimum approach distance shall be reduced to a distance within the designed working dimensions of the insulating barrier. This determination shall be made by a qualified person in accordance with the employer, local, or governmental requirements for work practices near energized equipment.

### **DANGER**

**DO NOT MANEUVER MACHINE OR PERSONNEL INSIDE PROHIBITED ZONE (MAD). ASSUME ALL ELECTRICAL PARTS AND WIRING ARE ENERGIZED UNLESS KNOWN OTHERWISE.**

## SECTION 1 - SAFETY PRECAUTIONS

### Tipping Hazards

- Ensure that the ground conditions are adequate to support the maximum tire load indicated on the tire load decals located on the chassis adjacent to each wheel. Do not travel on unsupported surfaces.
- The user should be familiar with the driving surface before driving. Do not exceed the allowable sideslope and grade while driving

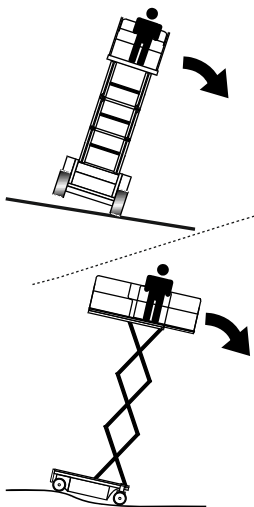

- Do not elevate platform or drive with platform elevated while on or near a sloping, uneven, or soft surface. Ensure machine is positioned on a firm uniform surface before elevating platform or driving with the platform in the elevated position.
- Before driving on floors, bridges, trucks, and other surfaces, check allowable capacity of the surfaces.
- Never exceed the maximum work load as specified on the platform. Keep all loads within the confines of the platform, unless authorized by JLG.
- Keep the chassis of the machine a minimum of 0.6m (2 ft.) from holes, bumps, drop-offs, obstructions, debris, concealed holes, and other potential hazards at the ground level.
- Never attempt to use the machine as a crane. Do not tie-off machine to any adjacent structure. Never attach wire, cable, or any similar items to platform.
- Do not cover the platform sides or carry large surface-area items in the platform when operating outdoors. The addition of such items increases the exposed wind area of the machine.
- Do not increase the platform size with unauthorized deck extensions or attachments.

- If scissor arm assembly or platform is caught so that one or more wheels are off the ground, all persons must be removed before attempting to free the machine. Use cranes, forklift trucks, or other appropriate equipment to stabilize machine and remove personnel.

### Crushing and Collision Hazards

- Approved head gear must be worn by all operating and ground personnel.
- Keep hands and limbs out of the scissor arm assembly during operation.
- Watch for obstructions around machine and overhead when driving. Check clearances above, on sides, and bottom of platform when lifting or lowering platform.

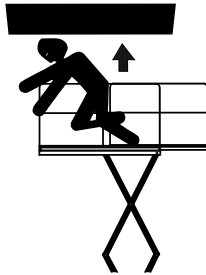

- During operation, keep all body parts inside platform railing.

- Always post a lookout when driving in areas where vision is obstructed.
- Keep non-operating personnel at least 1.8m. (6 ft.) away from machine during all driving operations.
- Under all travel conditions, the operator must limit travel speed according to conditions of ground surface, congestion, visibility, slope, location of personnel, and other factors causing hazards of collision or injury to personnel.
- Be aware of stopping distances in all drive speeds. When driving in high speed, switch to low speed before stopping. Travel grades in low speed only.
- Do not use high speed drive in restricted or close quarters or when driving in reverse.
- Exercise extreme caution at all times to prevent obstacles from striking or interfering with operating controls and persons in the platform.
- Ensure that operators of other overhead and floor level machines are aware of the aerial work platform's presence. Disconnect power to overhead cranes. Barricade floor area if necessary.
- Avoid operating over ground personnel. Warn personnel not to work, stand, or walk under a raised platform. Position barricades on floor as necessary.

## SECTION 1 - SAFETY PRECAUTIONS

---

### 1.4 TOWING, LIFTING, AND HAULING

- Never allow personnel in platform while towing, lifting, or hauling.
- This machine should not be towed, except in the event of emergency, malfunction, power failure, or loading/unloading. Refer to emergency towing procedures.
- Ensure platform is fully retracted and completely empty of tools prior to towing, lifting or hauling.
- When lifting machine with a forklift, position forks only at designated areas of the machine. Lift with a forklift of adequate capacity.
- Refer to Section 4 for lifting information.

### 1.5 MAINTENANCE

#### General

This section contains general safety precautions which must be observed during maintenance of this machine. Additional precautions to be observed during machine maintenance are inserted at the appropriate points in this manual and in the Service and Maintenance Manual. It is of utmost importance that maintenance personnel pay strict attention to these precautions to avoid possible injury to personnel or damage to the machine or property. A maintenance program must be established by a

qualified person and must be followed to ensure that the machine is safe.

#### Maintenance Hazards

- Shut off power to all controls and ensure that all operating systems are secured from inadvertent motion prior to performing any adjustments or repairs.
- Never work under an elevated platform until it has been fully lowered to the full down position, if possible, or otherwise supported and restrained from movement with appropriate safety props, blocking, or overhead supports.
- Always relieve hydraulic pressure from all hydraulic circuits before loosening or removing hydraulic components.
- Always disconnect batteries when servicing electrical components or when performing welding on the machine.
- Shut down the engine (if equipped) while fuel tanks are being filled.
- Ensure replacement parts or components are identical or equivalent to original parts or components.
- Never attempt to move heavy parts without the aid of a mechanical device. Do not allow heavy objects to rest in an unstable position. Ensure adequate support is provided when raising components of the machine.

- Remove all rings, watches, and jewelry when performing any maintenance. Do not wear loose fitting clothing or long hair unrestrained which may become caught or entangled in equipment.
- Use only clean approved non-flammable cleaning solvents.
- Never alter, remove, or substitute any items such as counterweights, tires, batteries, platforms or other items that may reduce or affect the overall weight or stability of the machine.
- Reference the Service and Maintenance Manual for the weights of critical stability items.

### **WARNING**

**MODIFICATION OR ALTERATION OF AN AERIAL WORK PLATFORM SHALL BE MADE ONLY WITH PRIOR WRITTEN PERMISSION FROM THE MANUFACTURER.**

### **Battery Hazards**

- Always disconnect batteries when servicing electrical components or when performing welding on the machine.
- Do not allow smoking, open flame, or sparks near battery during charging or servicing.
- Do not contact tools or other metal objects across the battery terminals.

- Always wear hand, eye, and face protection when servicing batteries. Ensure that battery acid does not come in contact with skin or clothing.

### **WARNING**

**BATTERY FLUID IS HIGHLY CORROSIVE. AVOID CONTACT WITH SKIN AND CLOTHING AT ALL TIMES. IMMEDIATELY RINSE ANY CONTACTED AREA WITH CLEAN WATER AND SEEK MEDICAL ATTENTION.**

- Charge batteries only in a well ventilated area.
- Avoid overfilling the battery fluid level. Add distilled water to batteries only after the batteries are fully charged.

**This page intentionally left blank.**

## **SECTION 2. USER RESPONSIBILITIES, MACHINE PREPARATION AND INSPECTION**

### **2.1 PERSONNEL TRAINING**

The aerial platform is a personnel handling device; so it is necessary that it be operated and maintained only by trained personnel.

Persons under the influence of drugs or alcohol or who are subject to seizures, dizziness or loss of physical control must not operate this machine.

#### **Operator Training**

Operator training must cover:

1. Use and limitations of the controls in the platform and at the ground, emergency controls and safety systems.
2. Control labels, instructions, and warnings on the machine.
3. Rules of the employer and government regulations.
4. Use of approved fall protection equipment.
5. Enough knowledge of the mechanical operation of the machine to recognize a malfunction or potential malfunction.

6. The safest means to operate the machine where overhead obstructions, other moving equipment, and obstacles, depressions, holes, drop-offs.
7. Means to avoid the hazards of unprotected electrical conductors.
8. Specific job requirements or machine application.

#### **Training Supervision**

Training must be done under the supervision of a qualified person in an open area free of obstructions until the trainee has developed the ability to safely control and operate the machine.

#### **Operator Responsibility**

The operator must be instructed that he/she has the responsibility and authority to shut down the machine in case of a malfunction or other unsafe condition of either the machine or the job site.

## **2.2 PREPARATION, INSPECTION, AND MAINTENANCE**

The following table covers the periodic machine inspections and maintenance recommended by JLG Industries, Inc. Consult local regulations for further requirements for aerial work platforms. The frequency of inspections and maintenance must be increased as necessary when the machine is used in a harsh or hostile environment, if the machine is used with increased frequency, or if the machine is used in a severe manner.

### **NOTICE**

**JLG INDUSTRIES, INC. RECOGNIZES A FACTORY-TRAINED SERVICE TECHNICIAN AS A PERSON WHO HAS SUCCESSFULLY COMPLETED THE JLG SERVICE TRAINING SCHOOL FOR THE SPECIFIC JLG PRODUCT MODEL.**



## SECTION 2 - USER RESPONSIBILITIES, MACHINE PREPARATION AND INSPECTION

**Table 2-1. Inspection and Maintenance Table**

Type	Frequency	Primary Responsibility	Service Qualification	Reference
Pre-Start Inspection	Before using each day; or whenever there's an Operator change.	User or Operator	User or Operator	Operator and Safety Manual
Pre-Delivery Inspection (See Note)	Before each sale, lease, or rental delivery.	Owner, Dealer, or User	Qualified JLG Mechanic	Service and Maintenance Manual and applicable JLG inspection form
Frequent Inspection	In service for 3 months or 150 hours, whichever comes first; or Out of service for a period of more than 3 months; or Purchased used.	Owner, Dealer, or User	Qualified JLG Mechanic	Service and Maintenance Manual and applicable JLG inspection form
Annual Machine Inspection (See Note)	Annually, no later than 13 months from the date of prior inspection.	Owner, Dealer, or User	Factory Trained Service Technician (Recommended)	Service and Maintenance Manual and applicable JLG inspection form
Preventative Maintenance	At intervals as specified in the Service and Maintenance Manual.	Owner, Dealer, or User	Qualified JLG Mechanic	Service and Maintenance Manual
<b>NOTE:</b> Inspection forms are available from JLG. Use the Service and Maintenance Manual to perform inspections.				

## SECTION 2 - USER RESPONSIBILITIES, MACHINE PREPARATION AND INSPECTION

### 2.3 PRE-START INSPECTION

The Pre-Start Inspection should include each of the following:

1. **Cleanliness** – Check all surfaces for leakage (oil, fuel, or battery fluid) or foreign objects. Report any leakage to the proper maintenance personnel.
2. **Structure** - Inspect the machine structure for dents, damage, weld or parent metal cracks or other discrepancies.

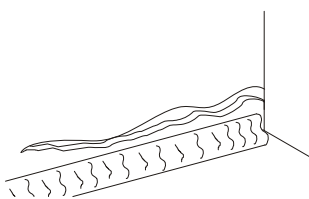

Parent Metal Crack

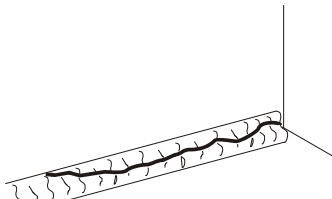

Weld Crack

3. **Decals and Placards** – Check all for cleanliness and legibility. Make sure none of the decals and placards are missing. Make sure all illegible decals and placards are cleaned or replaced.

4. **Operators and Safety Manuals** – Make sure a copy of the Operator and Safety Manual is enclosed in the weather resistant storage container.
5. **“Walk-Around” Inspection** – Refer to Figure 2-1.
6. **Battery** – Charge as required.
7. **Fuel** - (Combustion Engine Powered Machines) – Add the proper fuel as necessary.
8. **Engine Oil Supply** - Ensure that the engine oil level is at the full mark on the dipstick and the filler cap is secure
9. **Fluid Levels** - Be sure to check the engine oil and the hydraulic oil levels.
10. **Accessories/Attachments** - Reference the Operator and Safety Manual of each attachment or accessory installed upon the machine for specific inspection, operation, and maintenance instructions.
11. **Function Check** – Once the “Walk-Around” Inspection is complete, perform a functional check of all systems in an area free of overhead and ground level obstructions. Refer to Section 4 for more specific instructions on the operation of each function.

### Preparing the Machine for Operation

#### Emergency Ground Control Station

1. Turn key-switch to ground control select.
2. Pull emergency stop switch to the On position.
3. Check the function of the protective scissor cage.

#### Platform Control Box

1. Ensure the control box is connected at the platform.
2. Complete pre-operational checks:
  - Check all functions
  - Machine should not be drivable with outriggers extended.
  - Check all limit switches
  - Check the emergency-STOP button
  - Check the automatic self levelling

### **WARNING**

**IF THE MACHINE DOES NOT OPERATE PROPERLY, TURN OFF THE MACHINE IMMEDIATELY! REPORT THE PROBLEM TO THE PROPER MAINTENANCE PERSONNEL. DO NOT OPERATE THE MACHINE UNTIL IT IS DECLARED SAFE FOR OPERATION.**

### Function Check

Perform the Function Check as follows:

1. From the ground emergency control panel with no load in the platform:
  - a. Check for proper lifting and lowering of the platform.
  - b. Check manual descent.
  - c. Ensure that all machine functions are disabled when the Emergency Stop Button is activated.

**NOTE:** *Be sure the platform extension is retracted before lowering.*

2. From the platform control console:
  - a. Ensure that the control console is firmly secured in the proper location.
  - b. Check that all guards protecting the switches locks are in place.
  - c. Check the high drive cut out switch by raising the platform beyond the preset high drive speed cutout height of 90-96 in. (2.3 - 2.4m) and ensure the high drive speed cuts out.
  - d. Ensure that all machine functions are disabled when the Emergency Stop Button is pushed in.

## SECTION 2 - USER RESPONSIBILITIES, MACHINE PREPARATION AND INSPECTION

---

- e. Ensure that all LED's in the control box are working properly.
  - f. Check that the platform extension extends and retracts properly.
3. With the platform in the stowed position:
- a. Drive the machine on a level grade and stop to ensure the brakes hold.
  - b. To ensure proper operation of the tilt sensor, drive the machine onto a grade (front/rear) greater than the allowed tilt sensor preset (*see Table 2-2 below*), and attempt to raise the platform. The tilt alarm should sound when the platform elevation sensor detects the platform rising.

**Table 2-2. Tilt Sensor Preset Configuration**

Global	Australia Only (Special Option - Long Leveling Jack Machines)
5°	6°

## **2.4 DUAL FUEL SYSTEM (IF EQUIPPED)**

### **⚠ CAUTION**

**IT IS POSSIBLE TO SWITCH FROM ONE FUEL SOURCE TO THE OTHER WITHOUT ALLOWING THE ENGINE TO STOP. EXTREME CARE MUST BE TAKEN AND THE FOLLOWING INSTRUCTIONS MUST BE FOLLOWED.**

#### **Changing from Gasoline to LP Gas.**

1. Start the engine from the ground control station.
2. Open the hand valve on the LP Gas supply tank by turning counterclockwise.

### **⚠ CAUTION**

**BE SURE ALL GASOLINE IS EXHAUSTED BEFORE SWITCHING TO LP GAS.**

3. While the engine is operating, place the LPG/GAS SELECT switch at the platform control station to the LP Gas position.

#### **Changing from LP Gas to Gasoline.**

1. With the engine operating on LP gas under a no load condition, position the LPG/GAS SELECT switch at the platform control station to the GAS SELECT position.
2. If the engine 'stumbles' because of a lack of gasoline, place the switch to the LPG position until the engine regains smoothness, then return the switch to the GAS SELECT position. Repeat as necessary until the engine runs smoothly on gasoline.

Close the hand valve on the LP gas supply tank by turning clockwise.

## SECTION 2 - USER RESPONSIBILITIES, MACHINE PREPARATION AND INSPECTION

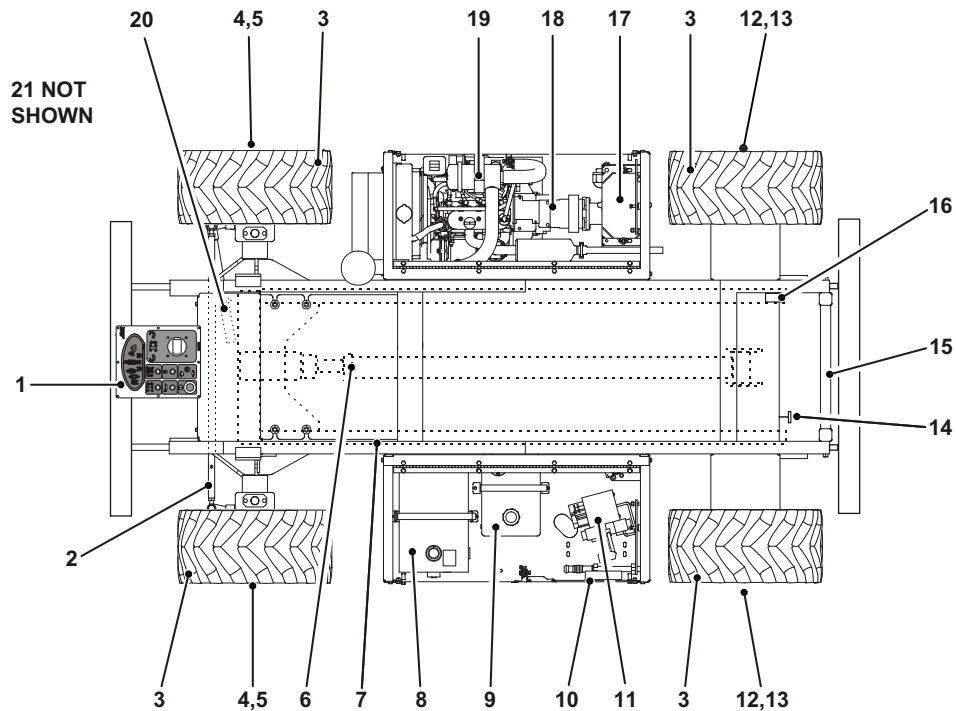

Figure 2-1. Walk Around Inspection Diagram

## SECTION 2 - USER RESPONSIBILITIES, MACHINE PREPARATION AND INSPECTION

### GENERAL

Begin the “Walk-Around Inspection” at Item 1, as noted on the diagram. Continue to the right (counterclockwise viewed from top) checking each item in sequence for the conditions listed in the “Walk-Around Inspection Checklist”.

#### **WARNING**

**TO AVOID POSSIBLE INJURY, BE SURE MACHINE POWER IS “OFF” DURING “WALK-AROUND INSPECTION”.**

#### **NOTICE**

**DO NOT OVERLOOK VISUAL INSPECTION OF CHASSIS UNDERSIDE. CHECKING THIS AREA OFTEN RESULTS IN DISCOVERY OF CONDITIONS WHICH COULD CAUSE EXTENSIVE MACHINE DAMAGE.**

**NOTE:** *On each item, make sure there are no loose or missing parts, that they are securely fastened, and that no visible damage exists in addition to any other criteria mentioned.*

1. Platform Controls - Properly secured, no loose or missing parts, no visible damage. Placards secure and legible, control switches return to neutral. Control markings legible, manual in manual storage box.
2. Steer Linkage - See Note.
3. Wheels and Tires - Properly secured, no missing lug nuts. Refer to section 6, Tires and Wheels. Inspect wheels for damage and corrosion.
4. Drive Motor, Left Front (4 Wheel Drive) - See Note. No evidence of leakage.
5. Drive Brake, Left Front (4 Wheel Drive) - See Note. No evidence of leakage.
6. Lift Cylinder - See Note.
7. Scissor Arms and Sliding Wear Pads - Properly secured, no visible damage, evidence of proper lubrication. Inspect scissor arm guards for damage and proper installation.
8. Hydraulic Reservoir - No visible damage or missing parts, No evidence of leaks. recommended oil level in sight glass. Breather cap secure and working.

Figure 2-2. Walk Around Inspection Points - Sheet 1

## **SECTION 2 - USER RESPONSIBILITIES, MACHINE PREPARATION AND INSPECTION**

---

9. Fuel Tank (Gasoline or Diesel Engine) - Filler cap secure, sight gauge visible, no damage or leaks.
10. Ground Controls - Switches operable, no visible damage, placards secure and legible.
11. Control Valve - See Note.
12. Drive Motor, Left Rear - See Note.
13. Drive Brake, Left Rear - No loose or missing parts, no visible damage, no evidence of leakage.
14. Manual Descent Cable and Pull Handle - See Note.
15. Ladder - No damage, securely attached.
16. Speed Cutout Switch - No visible damage, properly secured.
17. Battery Installation (Gasoline or Diesel Engine) - Proper electrolyte level, cables secure, no damage or corrosion. Hold-downs secure.
18. Hydraulic Pump - Pump properly secured, no visible damage, no evidence of leakage. Hoses and fittings properly secured, no visible damage, no evidence of leaks.
19. Engine Installation - Engine oil to full mark on dipstick, oil filler cap secure. Muffler/exhaust system properly secured, no leakage. Air filter assembly secure, no loose or missing parts, element clean. Radiator cap secure, coolant to correct level.
20. Steer Cylinder and Tie Rod Ends - No loose or missing parts, no visible damage. No steer cylinder leaks or damage.
21. Platform Assembly - See Note. Platform deck extension operates properly

**Figure 2-3. Walk Around Inspection Points - Sheet 2**



## **SECTION 3. USER RESPONSIBILITIES AND MACHINE CONTROL**

### **3.1 GENERAL**

#### **NOTICE**

**THE MANUFACTURER HAS NO DIRECT CONTROL OVER MACHINE APPLICATION AND OPERATION, CONFORMANCE WITH GOOD SAFETY PRACTICES IN THESE AREAS IS THE RESPONSIBILITY OF THE USER AND HIS OPERATING PERSONNEL.**

This section provides the necessary information needed to understand control functions. Included in this section are the operating characteristics and limitations, and functions and purposes of controls and indicators. It is important that the user read and understand the proper procedures before operating the machine. These procedures will aid in obtaining optimum service life and safe operation.

### **3.2 OPERATING CHARACTERISTICS AND LIMITATIONS**

#### **General**

A thorough knowledge of the operating characteristics and limitations of the machine is always the first requirement for any user, regardless of user's experience with similar types of equipment.

#### **Placards**

Important points to remember during operation are provided at the control stations by DANGER, WARNING, CAUTION, IMPORTANT and INSTRUCTION placards. This information is placed at various locations for the express purpose of alerting personnel of potential hazards constituted by the operating characteristics and load limitations of the machine. See foreword for definitions of the above placards.

#### **Capacities**

Raising platform above horizontal with or without any load in platform, is based on the following criteria:

1. Machine is positioned on a smooth, firm and level surface.
2. Load is within manufacturer's rated capacity.
3. All machine systems are functioning properly.

## SECTION 3 - USER RESPONSIBILITIES AND MACHINE CONTROL

---

### 3.3 CONTROLS AND INDICATORS

(Refer to Figure 3-1.)

The machine is equipped with control panels that use symbols instead of words to indicate control functions.

#### Ground Control Station



**DO NOT OPERATE FROM GROUND CONTROL STATION WITH PERSONNEL IN THE PLATFORM EXCEPT IN AN EMERGENCY.**

**PERFORM AS MANY PRE-OPERATIONAL CHECKS AND INSPECTIONS FROM THE GROUND CONTROL STATION AS POSSIBLE.**

**NOTE:** *When the machine is shut down for overnight parking or battery charging, the EMERGENCY STOP and POWER SELECTOR switches must be positioned to OFF to prevent draining the batteries.*

1. Power Selector Switch - A three position, key-operated power selector switch supplies operating power to the platform or ground controls, as selected. When positioned to platform, the switch provides power to the emergency stop switch at the platform controls. When positioned to ground, the switch provides power to the emergency stop switch at the ground controls. With the

power selector switch in the center off position, power is shut off to both platform and ground controls and the key can be removed to disable the machine.

**NOTE:** *With the Power Selector switch in the off position, the key can be removed in order to incapacitate the machine on the jobsite to avoid unauthorized use of the machine.*

*With the POWER SELECTOR switch positioned to GROUND, ground functions will operate at low speed at all times.*

**NOTE:** *Low speed is the default speed for all functions. When the platform is elevated, all functions operate in creep speed only.*

2. Latch - Allows box to be opened and closed.
3. Circuit Breaker - This 10 Amp circuit breaker, located on the left side of the platform control box, restores interrupted power to the platform controls.
4. Alternator LED - Illuminates when the alternator drops below a pre-set level.
5. Oil Pressure LED - Illuminates when the engine oil pressure drops below 7 psi (0.48 bar).

### SECTION 3 - USER RESPONSIBILITIES AND MACHINE CONTROL

---

6. Glow Plug Switch - A momentary contact, push button type switch that supplies electrical power to the engine's glow plugs, when depressed, to assist cold starting.
7. Water Temperature LED - Illuminates when engine water temperature becomes overheated.
8. Charge Pressure - Illuminates when the charge pressure drops below 70 psi (4.8 bar), indicating the charge filter is clogged and needs to be replaced. The indicator is also connected to a temperature sensor to prevent false signals from being generated when the hydraulic oil is below normal operating temperature.
9. Lift Switch - A three position, momentary contact Lift control switch provides raising and lowering of the platform when positioned to up or down.
10. Hourmeter -The machine may be equipped with an hourmeter to indicate the number of hours the machine has been operated.
11. Ignition/Emergency Stop Switch - A two-position, red, mushroom-shaped ignition/emergency stop switch, when positioned to ON with the power selector switch positioned to ground, furnishes operating power to the ground control station. In addition, the switch can be used to turn off power to the function controls in the event of an emergency. Power is turned on by pulling the switch out (on), and is turned off by pushing the switch in (off).
12. Start Switch - A momentary contact, push button type switch that supplies electrical power to the starter solenoid when the emergency stop switch is in the ON position and the start button is depressed.
13. Platform Overload LED (If Equipped) - Indicates the platform has been overloaded. An audible alarm will also signal when the platform is overloaded.

**NOTE:** *If the Overload Indicator is illuminated, all functions will be prevented from the platform controls. Using the ground controls or manual descent, fully lower the machine and reduce the weight in the platform so as to not exceed the rated workload indicated on the capacity decal.*

## SECTION 3 - USER RESPONSIBILITIES AND MACHINE CONTROL

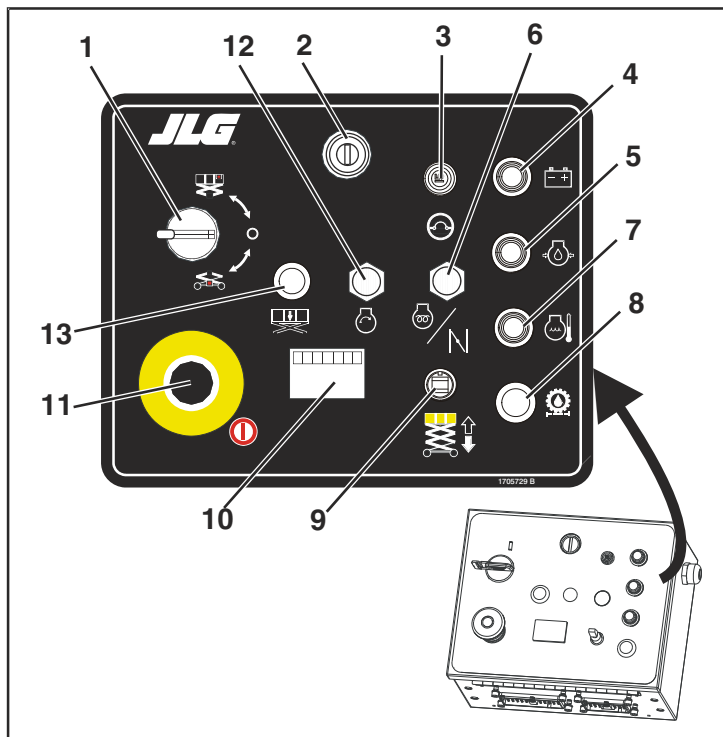

1. Platform/Ground Select Switch
2. Latch
3. Circuit Breaker
4. Alternator LED
5. Oil Pressure LED
6. Glow Plug Switch
7. Water Temperature LED
8. Hydraulic Charge Pressure LED
9. Lift Switch
10. Hourmeter
11. Emergency Stop Switch
12. Start Switch
13. Platform Overload LED (does not apply to all machines)

Figure 3-1. Ground - Control Station

### 3.4 PLATFORM CONTROL STATION

(Refer to Figure 3-2.)

1. Start Switch - A momentary contact, push button type switch that supplies electrical power to the starter solenoid when the emergency stop switch is in the on position and the start button is depressed.
2. Controller (Joystick) - The Joystick controls three functions: drive, lift, and drive/lift speed. The drive or the lift function switch must be selected prior to moving the machine with the Joystick. The speed is controlled by the travel distance of the Joystick.
3. Steer Switch - The thumb-operated steer switch on top of the Joystick handle activates the steer wheels in the direction it is moved (right or left).
4. Speed/Generator Switch - The three position speed/generator switch permits the operator to select either high range, low range or the generator (if equipped).

**NOTE:** *The machine cannot be lifted up from platform controls or driven when the generator is selected.*

*4 wheel drive is operational in **low drive** only.*

#### CAUTION

**DO NOT USE HIGH ENGINE SPEED WHEN DRIVING IN CLOSE QUARTERS OR WHEN DRIVING IN REVERSE.**

**NOTE:** *If machine is being operated in high range speed and the platform is raised above 90-96 in. (2.3-2.4m), the engine speed switch will cut-out returning drive speed to low until the platform is again lowered below the cut-out level.*

5. Emergency Stop Switch - A two-position, red, mushroom-shaped emergency stop switch functions to provide power to the platform control station and also to turn off power to the platform function controls in the event of an emergency. With the Power selector switch positioned to platform, power is turned on by pulling the switch out (on), and is turned off by pushing the switch in (off).

#### CAUTION

**DO NOT "LIFT DOWN" WITHOUT COMPLETELY RETRACTING THE PLATFORM EXTENSION.**

6. Lift Select Switch - The lift switch provides for raising and lowering the platform. Lift is activated by pressing the enable switch and positioning the joystick forward or backward.

### **SECTION 3 - USER RESPONSIBILITIES AND MACHINE CONTROL**

---

7. Drive Select Switch - The drive switch provides for driving the lift. Drive is activated by selecting the drive switch and positioning the joystick forward or backward.
8. Horn - (If Equipped) - This push-button switch, when activated, permits the operator to warn jobsite personnel when the machine is operating in the area.
9. Enable Trigger - Trigger on the front of the joystick must be held in to perform joystick controlled movements.
10. Glow Plug Switch - Glow Plug Switch - A momentary contact, push button type switch that supplies electrical power to the engine's glow plugs, when depressed, to assist cold starting.
11. Platform Overload LED (*does not apply to all machines*) - Illuminates when platform becomes overloaded. When LED illuminates, immediately remove excess weight from platform to continue safe operation.

## SECTION 3 - USER RESPONSIBILITIES AND MACHINE CONTROL

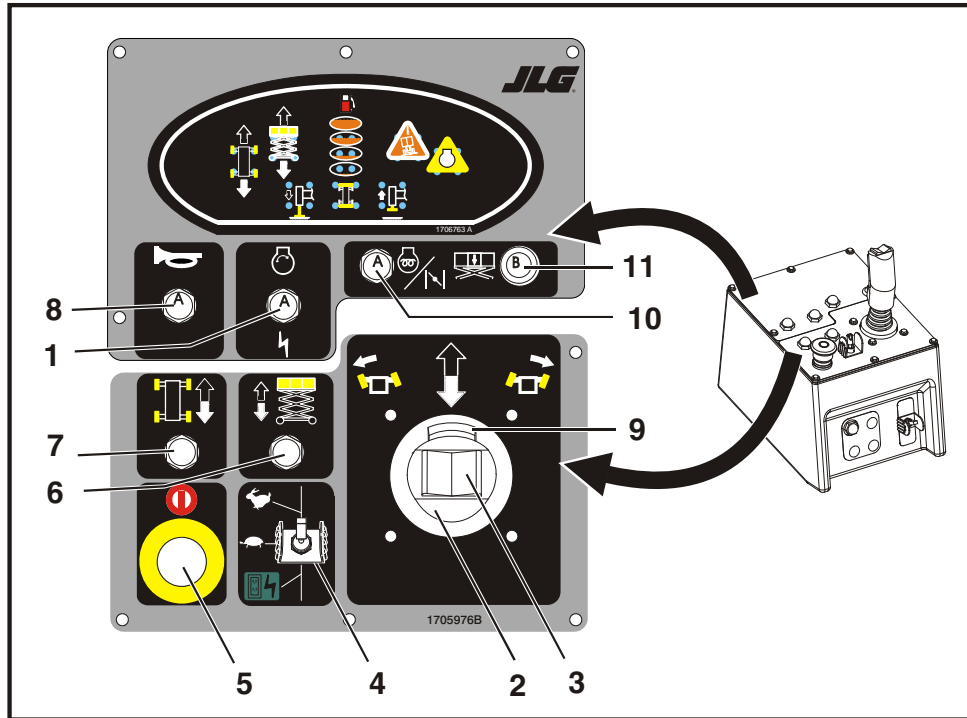

1. Start Switch
2. Joystick
3. Steer Switch
4. Speed/Generator Switch
5. Emergency Stop Switch
6. Lift Switch
7. Drive Switch
8. Horn
9. Enable Trigger
10. Glow Plug Switch
11. Platform Overload LED

Figure 3-2. Platform - Control Station

## SECTION 3 - USER RESPONSIBILITIES AND MACHINE CONTROL

---

### Platform Control Front Panel

*(Refer to Figure 3-3.)*

1. Fuel/Glow Plug Selector Switch - Selects which fuel source will be used. LPG vs. Gasoline or Diesel for diesel machines.
2. Auto Leveling Jacks - The leveling jacks switch is located on the front of the platform control box. When depressed, the outrigger light will illuminate on the indicator pad. Moving the control handle forward will lower the leveling jacks. Moving the control handle backward will raise the leveling jacks. Once the machine is level, the jacks will discontinue extending and the jack set light will illuminate.

**NOTE:** *After initial ground contact is made, the auto level function will pause 2-5 seconds and then begin to properly level the machine to the specified market specification. Once level, the tilt light on the platform control box will stop blinking.*

**NOTE:** *There is an override feature on the Auto Leveling system that allows the operator to adjust (trim) the level of the machine to the left or right when the platform is completely lowered. Use the following instructions to adjust the level of the machine.*

- a. Select the leveling jack selection switch and squeeze the red trigger switch on the controller.
- b. To adjust the leveling jacks to the left, activate the switch on top of the controller to the left. To adjust to the right, activate the switch on top of the controller to the right. The leveling jack indicator light for the side selected will be lit.



## SECTION 3 - USER RESPONSIBILITIES AND MACHINE CONTROL

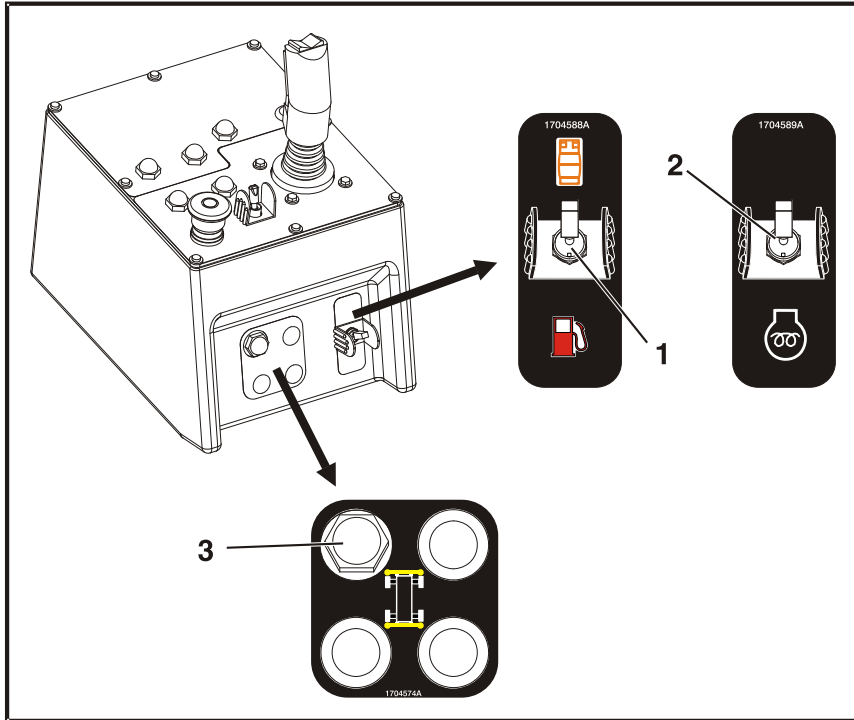

1. Dual Fuel Selector Switch
2. Diesel Fuel Selector Switch
3. Outrigger Switch

Figure 3-3. Platform - Control Front Panel

## SECTION 3 - USER RESPONSIBILITIES AND MACHINE CONTROL

---

### Indicator Panel LED's

(Refer to Figure 3-4.)

1. Drive - This LED will illuminate when the drive select button is activated.
2. Lift - This LED will illuminate when the lift select button is activated.
3. Fuel Gauge - This series of LED's give the operator a visual of the amount of fuel remaining.
4. Tilt Alarm Warning Light - This red warning light on the control panel will illuminate when the chassis is on a severe slope.
5. Engine/Filter Distress Light - This warning light, when illuminated, warns the operator of an engine or hydraulic system fault condition. A bank of warning lights, located at the ground control station, indicates the specific fault condition to the operator. The indicator lights are: Alternator, Charge Pressure, Engine Temperature, Oil Pressure, and Return Filter.
6. Leveling Jacks (retracted) - This set of lights will illuminate once all the leveling jacks are retracted.
7. Leveling Jacks (extended) - This set of lights will illuminate once all the leveling jacks are extended.

### **NOTICE**

FOR MACHINES EQUIPPED WITH THE YANMAR DIESEL ENGINE, THE TIMER RELAY MUST SEAT THE FUEL SOLENOID WITH ITS INITIAL PULSE, OR THE ENGINE WILL NOT START. PROLONGED NO-START IS AN INDICATION THAT THE FUEL SOLENOID HAS NOT SEATED OR THAT THERE IS NO FUEL. IF THE ENGINE FAILS TO START, THE START SWITCH MUST BE RE-CYCLED TO PULSE THE FUEL SOLENOID INTO THE SEATED POSITION.

### **⚠ CAUTION**

IF TILT ALARM IS ON WHEN PLATFORM IS RAISED, LOWER PLATFORM COMPLETELY, THEN REPOSITION MACHINE SO THAT IT IS LEVEL BEFORE RAISING PLATFORM.

### **⚠ CAUTION**

DO NOT OPERATE MACHINE IF HIGH DRIVE SPEED OPERATES WHEN PLATFORM IS RAISED ABOVE THE STOWED POSITION.

## SECTION 3 - USER RESPONSIBILITIES AND MACHINE CONTROL

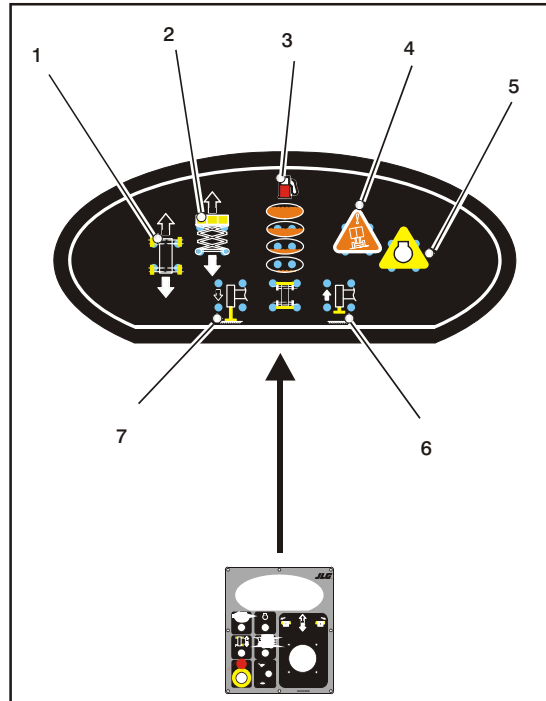

1. Drive
2. Lift
3. Fuel Gauge
4. Tilt
5. Engine Distress
6. Leveling Jacks (Retracted)
7. Leveling Jacks (Set)

Figure 3-4. Platform - Indicator Panel

## SECTION 3 - USER RESPONSIBILITIES AND MACHINE CONTROL

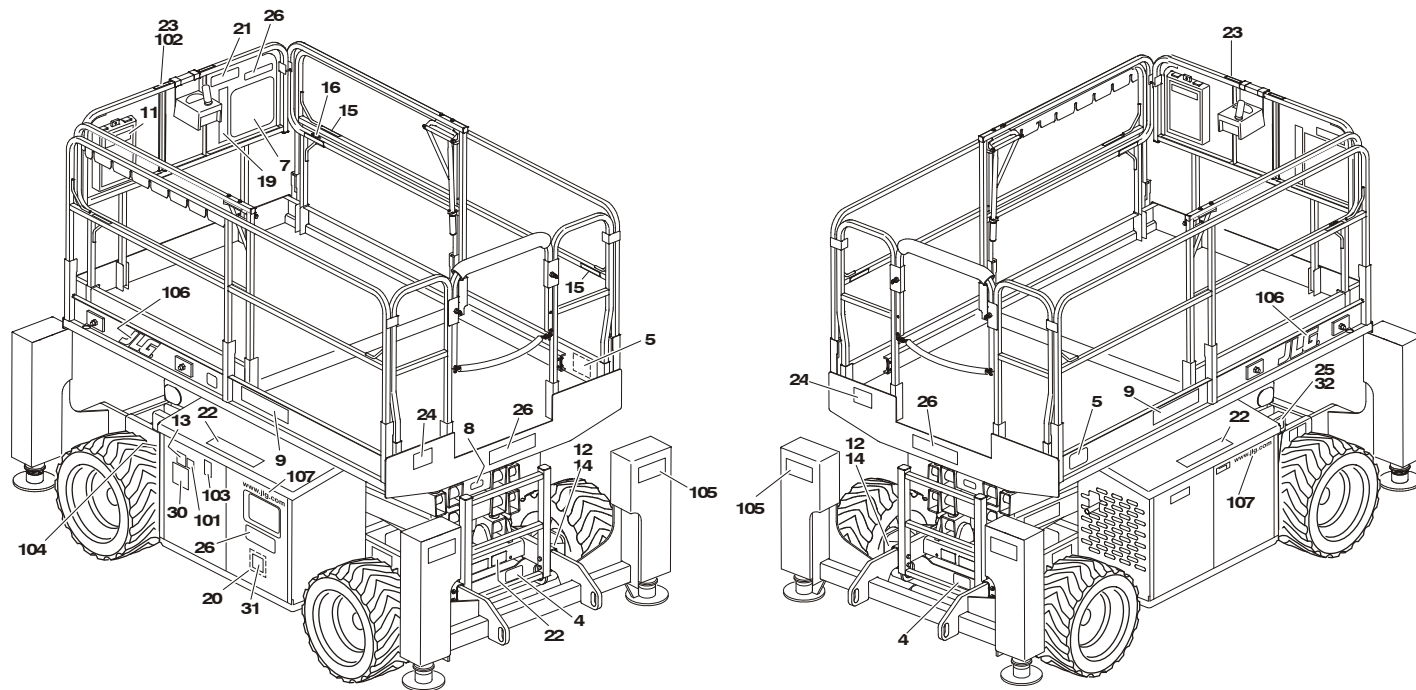

Figure 3-5. Decal Location (ANSI)

## SECTION 3 - USER RESPONSIBILITIES AND MACHINE CONTROL

**Table 3-1. Decal Legend (ANSI)**

Item #	0259792-8
1-3	--
4	1702153
5	1702631
6	--
7	1703816
8	1704138
9	1704529
10	--
11	
Prior to S/N 102883	1703788
S/N 102883 to Present	1701509
12	1701500
13	1703812
14	1703814
15	1704277
16	1703819
17-18	--
19	1704480
20	1704556
21	1703696
22	1703818

**Table 3-1. Decal Legend (ANSI)**

Item #	0259792-8
23	1703821
24	3251813
25	--
26	3252689
27-29	--
30	1704412
31	1001131270
32	--
101	
(Optional)	1702788
102	
Dual Fuel	1702961
Diesel	1702962
103	
Dual Fuel	1701542
Diesel	1701505
104	
(Dual Fuel Only)	1700818
105	1701214
106	1702773
107	1704885

## SECTION 3 - USER RESPONSIBILITIES AND MACHINE CONTROL

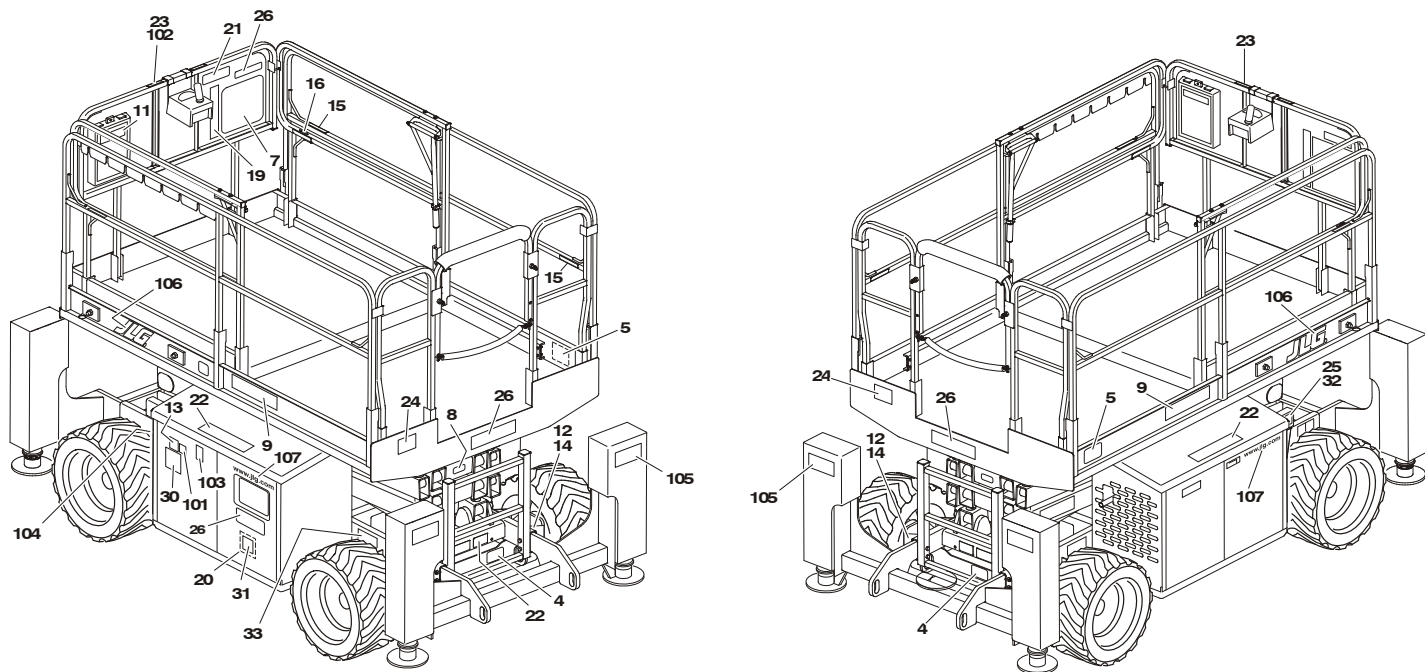

Figure 3-6. Decal Location (ANSI Export)

## SECTION 3 - USER RESPONSIBILITIES AND MACHINE CONTROL

**Table 3-2. Decal Legend (ANSI Export)**

Item #	Brazil 0259795-7	CSA 0272257-3	Latin American 0259794-7
1-3	--	--	--
4	1704008	1704006	1704007
5	1702631	1702631	1702631
6	--	--	--
7	1704699	1704684	1704691
8	1704138	1704138	1704138
9	1704529	1704529	1704529
10	--	--	--
11			
Prior to S/N 102883	1703788	1703788	1703788
S/N 102883 to Present	1701509	1701509	1701509
12	1703811	1703811	1703811
13	1703812	1703812	1703812
14	1703814	1703814	1703814
15	1704277	1704277	1704277
16	1703819	1703819	1703819
17-18	--	--	--
19	1704700	1704685	1704692
20	1704623	1704688	1704695
21	1704748	1704597	1704598
22	1704701	1704686	1704693
23	1704702	1704687	1704694
24	3251813	3251813	3251813

**Table 3-2. Decal Legend (ANSI Export)**

Item #	Brazil 0259795-7	CSA 0272257-3	Latin American 0259794-7
25	--	--	--
26	3252689	3252689	3252689
27-29	--	--	--
30	1704412	1704412	1704412
31	--	1001131270	--
32	--	--	--
33	--	1705303	--
101 (Optional)	1702788	1702788	1702788
102 Dual Fuel Diesel	1702961 1702962	1702961 1702962	1702961 1702962
103 Dual Fuel Diesel	1701542 1701505	1701542 1701505	1701542 1701505
104 (Dual Fuel Only) English English/Spanish Language English/French Language	1700818 1702720 1704271	1700818 1702720 1704271	1700818 1702720 1704271
105	1704698	1704690	1704697
106	1702773	1702773	1702773
107	1704885	1704885	1704885

## SECTION 3 - USER RESPONSIBILITIES AND MACHINE CONTROL

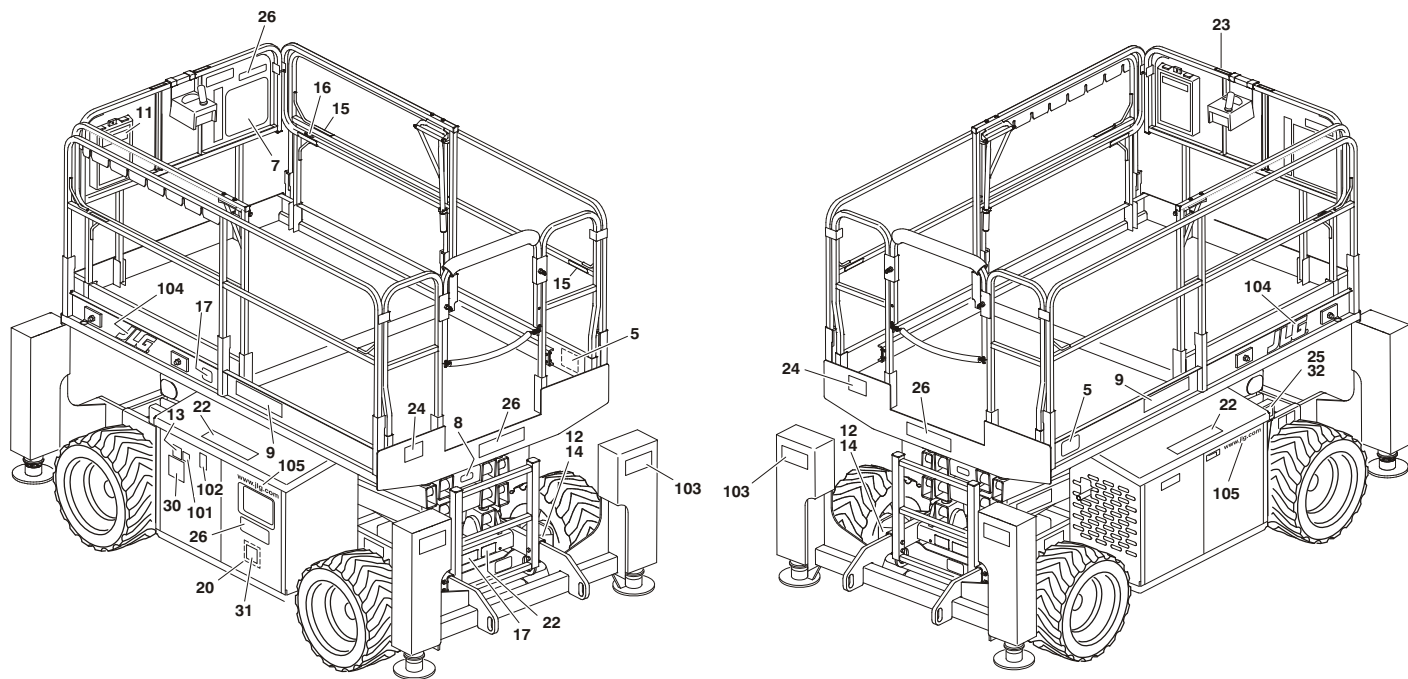

Figure 3-7. Decal Location (CE/AUS)



## SECTION 3 - USER RESPONSIBILITIES AND MACHINE CONTROL

**Table 3-3. Decal Legend - (CE/AUS)**

Item #	CE/AUS 0275087-2
1-4	--
5	1702631
6	--
7	1704548
8	1704138
9	1704529
10	--
11	
Prior to S/N 102883	1703788
S/N 102883 to Present	1701509
12	1703811
13	1703812
14	1703814
15	1704277
16	1703819
17	1705084
18-19	--
20	1706332
21	--

**Table 3-3. Decal Legend - (CE/AUS)**

Item #	CE/AUS 0275087-2
22	1706338
23	--
24	3251813
25	3252533 (CE) 3252534 (AUS)
26	1705671
27-29	--
30	1704412
31	--
101 (Optional)	1702788
102	1701505
103	1701785
104	1702773
105	1704885

This page left blank intentionally.

## SECTION 4. MACHINE OPERATION

### 4.1 DESCRIPTION

This machine is a self-propelled hydraulic lift equipped with a work platform on an elevating scissor mechanism. Vibrations emitted by these machines are not hazardous to an operator in the work platform. The equivalent continuous A-Weighted sound pressure level at the work platform is less than 70 dB(A).

The primary operator control station is in the platform. From this control station, the operator can drive and steer the machine in both forward and reverse directions. The machine has a Ground Control Station which will override the Platform Control Station. Ground Controls operate lift and lower and are to be used in an emergency to lower the platform to the ground should the operator in the platform be unable to do so. Ground Control is also to be used in Pre-Start Inspection.

### 4.2 ENGINE OPERATION

#### Power Selector Switch

The power selector switch functions to direct electrical power to the desired control station. With the switch in the ground position, power is supplied to the emergency stop switch at the ground control station. When the switch is in the platform position, power is supplied to the emergency stop switch at the platform control station. The switch should be in the off position when parking the machine overnight.

#### Emergency Stop Switch

This switch, when in the on (out) position, provides electrical power to the ground controls or platform controls, as applicable. In addition, the switch can be used to turn off power (push the switch IN) to the function controls in the event of an emergency.

#### Starting Procedure

**NOTE:** *Initial starting should always be performed from the Ground Control Station.*

## SECTION 4 - MACHINE OPERATION

---

1. Check engine oil before attempting to start engine; if necessary, add oil in accordance with Engine Manufacturers Manual.
2. Pull out the red EMERGENCY STOP switch (ON).
3. Position the PLATFORM/GROUND SELECT switch to the desired operating control station (PLATFORM or GROUND).
4. If operating a dual fuel machine, place the LPG/GASOLINE SELECT switch to the desired position.

**NOTE:** *If the LPG system is selected, ensure that the hand valve on the LPG supply tank is opened prior to attempting to start the engine.*

### **NOTICE**

**IF ENGINE FAILS TO START PROMPTLY, DO NOT CRANK FOR AN EXTENDED PERIOD. SHOULD ENGINE FAIL TO START ONCE AGAIN, ALLOW STARTER TO "COOL OFF" FOR 2 TO 3 MINUTES. IF ENGINE FAILS TO START AFTER SEVERAL ATTEMPTS, REFER TO ENGINE MAINTENANCE MANUAL.**

**IF STARTING MACHINE FROM THE PLATFORM CONTROL STATION, PLACE THE ENGINE SPEED CONTROL TO THE LOW POSITION PRIOR TO STARTING THE ENGINE.**

5. If starting the machine from the ground controls, position the EMERGENCY STOP switch to ON and depress the START button and hold until the engine starts. If starting from the platform controls, position the platform EMERGENCY STOP switch to ON and depress the START button and hold until the engine starts.

### **NOTICE**

**ALLOW ENGINE TO WARM-UP FOR A FEW MINUTES BEFORE APPLYING ANY LOAD.**

6. After the engine has had sufficient time to warm up, proceed with operation of the unit.

### 4.3 OPERATING CHARACTERISTICS

#### Leveling Jacks

The machine may be equipped with auto leveling jacks with a manual adjust feature. These leveling jacks are operated through one switch unlike the traditional four switch system. The leveling jacks are operated by a bang bang valve.

**NOTE:** *The engine speed will drop when the leveling jacks are activated.*

#### Auto Leveling

1. With the machine in the stowed position turn the power on, start machine and depress the leveling jack selection switch located on the front of the platform control box.
2. While squeezing the red trigger switch on the controller, move the controller forward.
3. Once the leveling jacks make contact with the ground surface there will be up to a 5 second delay before the actual auto leveling begins.

**NOTE:** *Due to varying ground conditions, there may be several delays between machine level corrections. Be sure ample*

*time is allowed for all leveling adjustments to be completed.*

4. Continue to engage the leveling jacks until the tilt light stops blinking and is no longer lit.

**NOTE:** *If you receive a 2/5 flash code through the system fault light at the platform control station the machine is unable to level. You must reposition and try again.*

5. To retract the leveling jacks, move the controller backward until the desired position is obtained.

**NOTE:** *The tilt light serves as an indicator that the machine is outside the allowable lifting operation. When the machine reaches a position within level of the specific market specification, the tilt light will go out. Once the light is out, the level adjustment of the machine may still be improved. (See Manual Level Adjustment (Trim) section).*

**NOTE:** *There is a limit switch that senses when all four cylinders are fully retracted and this will light up the four leveling jack lights in the platform control station.*

*The proximity sensor will not allow the jacks to be extended or retracted when the machine is elevated. If there is a proximity sensor failure you cannot use the leveling jacks.*

## SECTION 4 - MACHINE OPERATION

---

### Manual Level Adjustment (Trim)

**NOTE:** *There is an override feature on the Leveling Jack system that allows the operator to adjust (trim) the level of the machine to the left or right when the platform is completely lowered. Use the following instructions to adjust the level of the machine.*

6. With the machine in the stowed position turn the power on, start machine and depress the leveling jack selection switch located on the front of the platform control box.
7. To adjust (trim) the machine to the right, activate the steer switch on the top of the controller to the right until the desired position is reached.
8. To adjust (trim) the machine to the left, activate the steer switch on the top of the controller to the left until the desired position is reached.

**NOTE:** *Anytime the trim function is used there is a possibility that the machine may become out of level. At this time the machine will no longer lift but the machine can be lowered.*

**NOTE:** *The machine must be in the stowed position before the trim function is operable.*

### 4.4 PLATFORM

#### Raising



**DO NOT RAISE PLATFORM EXCEPT ON A SMOOTH, FIRM, AND LEVEL SURFACE, FREE OF OBSTRUCTIONS AND HOLES.**

1. If the machine is shut down, place the power selector switch to desired position (platform or ground).
2. Position the applicable emergency stop Switch to the on position.
3. If operating from the ground controls, position the lift switch to up and hold until desired elevation is achieved. If operating from the platform controls, press the enable switch then position the lift switch to up and hold until desired elevation is reached. The lift switch is part of the enable circuit, which supplies power to the lift switch for 3 seconds after the enable switch is pressed. If the lift switch is not activated within 3 seconds after the enable switch is pressed, power is removed from the circuit and the enable switch must be pressed again before activating the lift switch.

### Lowering

#### **WARNING**

**ENSURE SCISSOR ARM AREA IS FREE OF PERSONNEL PRIOR TO LOWERING PLATFORM.**

**ENSURE PLATFORM EXTENSION IS COMPLETELY RETRACTED PRIOR TO LOWERING PLATFORM.**

If operating from the ground controls, position the lift switch to down and hold until desired elevation is achieved or until platform is fully lowered.

If operating from the platform controls, press the lift switch and then position the joystick to down and hold until desired elevation is reached or until platform is fully lowered.

#### **WARNING**

**DO NOT 'LIFT DOWN' WITHOUT COMPLETELY RETRACTING THE PLATFORM EXTENSION.**

### Platform Extension

The machine is equipped with a mechanically extendable deck, which adds 3 ft (0.9 m) to the front of the platform, giving the operator better access to work-sites.

**To extend the deck**, squeeze the release lever on the handle on the left side of the platform to release the lock pin, then use the handle and handrail to push the extendable deck out.

**To retract the deck**, squeeze the release lever to release the lock pin and use the handle and handrail to pull and retract the deck.

Be sure the lock pin is locked in place after the deck is retracted.

Maximum capacity of the deck extension is 300 lbs (136 kg).

#### **WARNING**

**DO NOT 'LIFT DOWN' WITHOUT COMPLETELY RETRACTING THE PLATFORM EXTENSION.**

### 4.5 DRIVING

#### **WARNING**

**DO NOT DRIVE WITH PLATFORM RAISED EXCEPT ON A SMOOTH, FIRM AND LEVEL SURFACE FREE OF OBSTRUCTIONS AND HOLES.**

**TO AVOID LOSS OF TRAVEL CONTROL OR UPSET ON GRADES AND SIDESLOPES, DO NOT DRIVE MACHINE ON GRADES EXCEEDING THOSE SPECIFIED ON CAUTION PLACARD AT PLATFORM.**

**TRAVEL GRADES IN “LOW” DRIVE SPEED ONLY. USE EXTREME CAUTION WHEN DRIVING IN REVERSE AND AT ALL TIMES WHEN DRIVING WITH PLATFORM ELEVATED AND ESPECIALLY WHEN DRIVING WITH ANY PART OF MACHINE WITHIN 6 FEET (1.8 M) OF AN OBSTRUCTION.**

#### Steering

To steer the machine, the thumb operated steer control switch on the controller handle is positioned to the right for traveling right, or to the left for traveling left. When released, the switch will return to the center-off position and the wheels will remain in the previously selected position. To return the wheels to the straightened position, the switch must be activated in the opposite direction until the wheels are centered.

#### Driving Forward

1. Place the power selector switch at the ground control station to platform.
2. Position the emergency stop switch at the platform control station to the on position.
3. Press the drive switch and move the joystick forward and hold for the duration of travel.  
Drive speed is determined by the distance the control handle is moved from the center off position.  
For additional drive speed, position the high engine speed switch to high while operating in the drive forward mode.

#### Driving in Reverse

1. Position the power selector switch at the ground control station to platform.
2. Position the emergency stop switch at the platform control station to the on position.
3. Press the drive switch and move the drive controller rearward and hold for the duration of travel.  
Drive speed is determined by the distance the control handle is moved from the center off position.  
Do not activate the high engine speed switch when traveling in reverse.



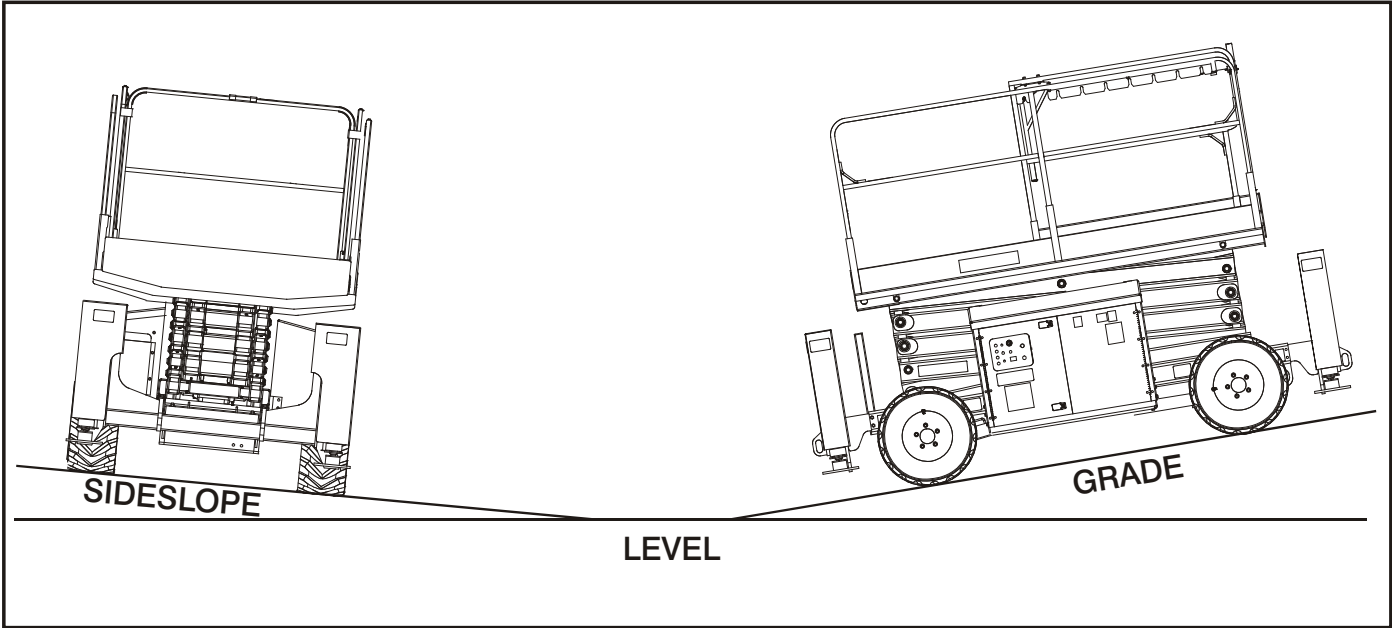

**Figure 4-1. Grade and Sideslope Depiction**

## SECTION 4 - MACHINE OPERATION

---

### 4.6 PARKING AND STOWING

Park and stow the machine as follows:

1. Drive the machine to a reasonably well-protected and well-ventilated area.
2. Ensure the platform is fully lowered.
3. Position the emergency stop switch to the off position.
4. If necessary, cover the instruction placards, caution and warning decals so that they will be protected from hostile environment.
5. Chock at least two wheels when parking the machine for an extended period of time.
6. Turn the power selector switch to off and remove the key to disable the machine from unauthorized use.

### 4.7 PLATFORM LOADING

The platform maximum rated load capacity is shown on a placard located on the platform and is based upon the following criteria:

1. The machine is positioned on a smooth, firm and level surface.
2. All braking devices are engaged.

3. The maximum platform capacity in its standard configuration is 1,250 lb. (570 kg). See note.
4. The maximum capacity of the manual platform extension is 300lb. (140 kg).

**NOTE:** *It is important to remember that the load should be evenly distributed on the platform. The load should be placed near the center of the platform when possible.*

### 4.8 SAFETY PROP



**THE SAFETY PROP MUST BE USED WHENEVER MAINTENANCE PERFORMED ON THE MACHINE REQUIRES THE SCISSOR ARMS TO BE RAISED.**

To engage the safety prop, with no load in the platform, raise the platform, then rotate the prop clockwise until it hangs vertically. Lower the platform until the safety prop rests on the point provided on the frame. Maintenance can now begin.

To store the safety prop, raise the platform so that the prop can be rotated counterclockwise until it rests on the stop provided on the scissor arms.

## **4.9 TIE DOWN**

When transporting the machine, the platform extension must be fully retracted and the platform fully lowered in the stowed mode with the machine securely tied down to the truck or trailer deck. Four tie down eyes, one at each corner of the machine frame, are provided for machine tie-down.

### **Lifting**

If it becomes necessary to lift the machine, it is possible to do so from the tie down/lift lugs. These lugs enable the machine to be lifted using cranes or other suitable lifting devices.

**NOTE:** *If lifting becomes necessary from the lifting lugs, Jlg Industries Inc. recommends the use of a proper spreader bar to avoid damage to the machine.*

*Cranes or other lifting devices must be capable of handling 7660 lb (3475 kg)*

## **4.10 TOWING**

Although towing the machine is prohibited, provisions for moving the machine, in case of a malfunction or power failure, have been incorporated. The following procedures are to be used **ONLY** for emergency movement to a suitable maintenance area.

1. Chock the wheels securely.
2. Locate the brake cartridge on the hydraulic control valve, located adjacent to the hydraulic oil tank on the left side of the machine. Depress the plunger on the brake cartridge.
3. Locate the brake release pump, in front of the hydraulic control valve. Install the handle on the brake release pump and pump it to release the brake. Remove handle when finished.
4. Using suitable equipment for assistance, remove the chocks, winch or tow the machine to an appropriate maintenance area.

### **WARNING**

**USE EXTREME CAUTION WHEN OPENING THE TOW VALVE. THE DRIVE FUNCTION WILL STILL OPERATE WITH THE TOW VALVE OPEN, BUT THE BRAKE IS DISABLED. ENSURE THE TOW VALVE REMAINS CLOSED AT ALL TIMES, EXCEPT WHEN THE MACHINE IS BEING**

## **SECTION 4 - MACHINE OPERATION**

---

**TOWED. CLOSE THE TOW VALVE IMMEDIATELY AFTER TOWING IS COMPLETED.**

After moving the machine, complete the following procedures:

1. Position the machine on a firm, level surface.
2. Chock the wheels securely.
3. Turn knob counterclockwise to engage wheel brakes.
4. Turn the knob on the brake pump clockwise until tight.  
this places the machine back into normal operation
5. Remove the chocks from the wheels.

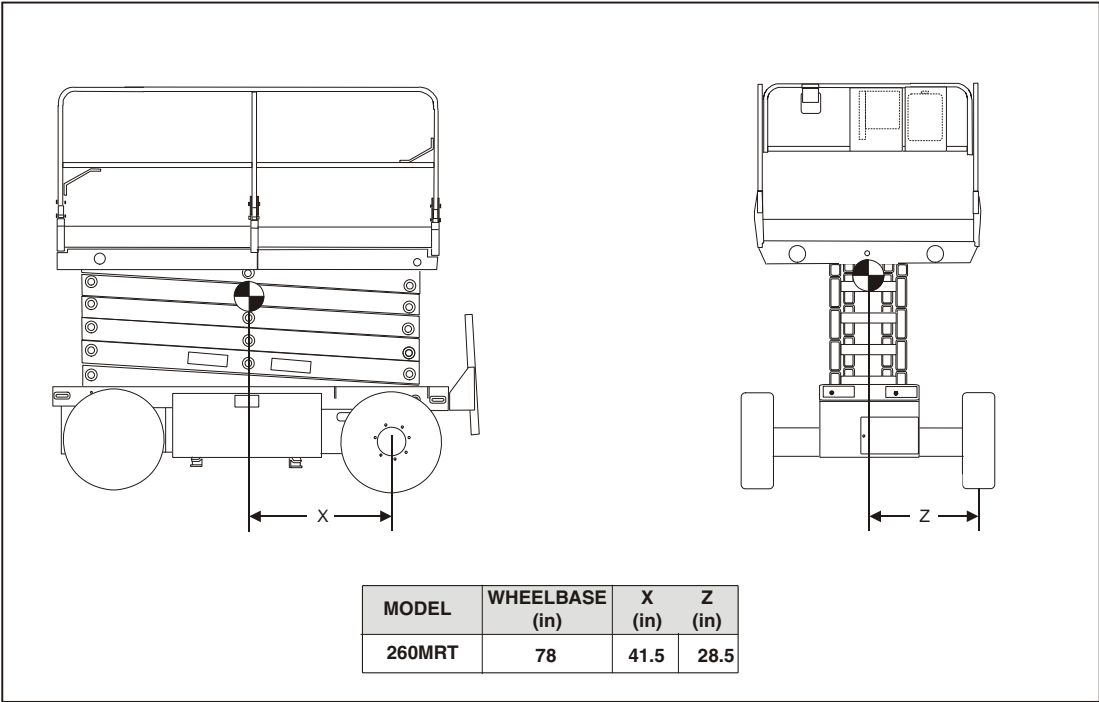

Figure 4-2. Lifting Chart

This page left blank intentionally.

## **SECTION 5. EMERGENCY PROCEDURES**

### **5.1 GENERAL**

This section provides information on the procedures to be followed and on the systems and controls to be used in the event an emergency situation is encountered during machine operation. Prior to operation of the machine and periodically thereafter, the entire operating manual, including this section, should be reviewed by all personnel whose responsibilities include any work or contact with the machine.

#### **Emergency Stop Switch**

These large red buttons, one located at the Ground Control Station and one at the Platform Control Station, will immediately stop the machine when depressed.

#### **⚠ WARNING**

**CHECK MACHINE DAILY TO MAKE SURE EMERGENCY STOP BUTTON IS IN PLACE AND THAT GROUND CONTROL INSTRUCTIONS ARE IN PLACE AND LEGIBLE. GROUND CONTROL STATION**

The Ground Control Station is located on the left side of the machine frame. The controls on this panel provide the means for overriding the platform controls and for controlling

the platform lift up and down functions from the ground. Place the power select switch in the ground position and operate the lift switch to lift up or down.

#### **Manual Descent**

The manual descent valve is used, in the event of total power failure, to lower the platform using gravity. The manual descent ring is located on the front of the machine frame, between the scissor arms. The ring is connected, by a cable, to the manual descent valve on the lift cylinder. Pulling the manual descent ring opens the valve spool, lowering the platform.

### **5.2 EMERGENCY OPERATION**

#### **Use of Ground Controls**

#### **NOTICE**

**KNOW HOW TO USE THE GROUND CONTROLS IN AN EMERGENCY SITUATION.**

Ground personnel must be thoroughly familiar with the machine operating characteristics and the ground control functions. Training should include operation of the machine,

## **SECTION 5 - EMERGENCY PROCEDURES**

---

review and understanding of this section and hands-on operation of the controls in simulated emergencies.

### **Operator Unable to Control Machine**

1. Operate the machine from ground controls **ONLY** with the assistance of other personnel and equipment (cranes, overhead hoists, etc.) as may be required to safely remove the danger or emergency condition.
2. Other qualified personnel on the platform may use the platform controls. **DO NOT CONTINUE OPERATION IF CONTROLS DO NOT FUNCTION NORMALLY.**
3. Cranes, forklift trucks or other equipment which may be available are to be used to remove platform occupants and stabilize motion of the machine in case machine controls are inadequate or malfunction when used.

### **Platform Caught Overhead**

If the platform becomes jammed or snagged in overhead structures or equipment, do not continue operation of the machine from either the platform or the ground until the operator and all personnel are safely moved to a secure location. Only then should an attempt be made to free the platform using any necessary equipment and personnel. Do not operate controls to cause one or more wheels to leave the ground.

### **Righting of Tipped Machine**

A forklift of suitable capacity or equivalent equipment should be placed under the elevated side of the chassis, with a crane or other suitable lifting equipment used to lift the platform while the chassis is lowered by the forklift or other equipment.

### **Post-Incident Inspection**

Following any incident, thoroughly inspect the machine and test all functions first from the ground controls, then from the platform controls. Do not lift above 10 feet (3 meters) until you are secure that all damage has been repaired, if required, and that all controls are operating correctly.



### **5.3 INCIDENT NOTIFICATION**

JLG Industries, Inc. must be notified immediately of any incident involving a JLG product. Even if no injury or property damage is evident, the factory should be contacted by telephone and provided with all necessary details.

USA: 877-JLG-SAFE (554-7233)

EUROPE: (44) 1 698 811005

AUSTRALIA: (61) 2 65 811111

E-mail: [productsafety@jlg.com](mailto:productsafety@jlg.com)

Failure to notify the manufacturer of an incident involving a JLG Industries product within 48 hours of such an occurrence may void any warranty consideration on that particular machine.

#### **NOTICE**

**FOLLOWING ANY ACCIDENT, THOROUGHLY INSPECT THE MACHINE AND TEST ALL FUNCTIONS FIRST FROM THE GROUND CONTROL STATION, THEN FROM THE PLATFORM CONTROL CONSOLE. DO NOT ELEVATE PLATFORM UNTIL YOU ARE SURE THAT ALL DAMAGE HAS BEEN REPAIRED, IF REQUIRED, AND THAT ALL CONTROLS ARE OPERATING CORRECTLY.**

This page left blank intentionally.

## **SECTION 6. GENERAL SPECIFICATIONS AND OPERATOR MAINTENANCE**

### **6.1 INTRODUCTION**

This section of the manual provides additional necessary information to the operator for proper operation and maintenance of this machine.

The maintenance portion of this section is intended as information to assist the machine operator to perform daily maintenance tasks only, and does not replace the more thorough Preventive Maintenance and Inspection Schedule included in the Service and Maintenance Manual.

#### **Other Publications Available Specific to this Machine:**

Service and Maintenance Manual (ANSI).....	3121108
Illustrated Parts Manual(ANSI).....	3121109
Service and Maintenance Manual (CE).....	3121801
Illustrated Parts Manual(CE).....	3121802

## SECTION 6 - GENERAL SPECIFICATIONS AND OPERATOR MAINTENANCE

### 6.2 OPERATING SPECIFICATIONS

**Table 6-1. Operating Specifications**

Maximum Occupants	2
Maximum Workload (Capacity) Extension Only:	1,250 lb (570 kg) 300 lb (140 kg)
Maximum Gradeability	35%
Maximum Side Slope (Plat. stowed)	5°
Maximum Platform Height	26 ft (8m)
Maximum Tire Load	2,600lb (1,180 kg)
Max. Ground Bearing Pressure	33 psi (2.3 kg/cm <sup>2</sup> )
Maximum Allowable Wind Speed	28 mph (12.5m/s)
Maximum Horizontal Manual Side Force: CE/AUS	187 lb force (832 N) 90 lb force (400 N)
Turning Radius: Inside Outside	7.1ft (2.1 m) 14.5 ft (4.4 m)
Wheelbase	6.6 ft (2 m)

**Table 6-1. Operating Specifications**

Gross Machine Weight (Approximate)	7,330 lb (3,325 kg)
Maximum Drive Speed	3.5 mph (5.6 kmh)
Drive Speed (slow) - sec./25ft (7.6 m)	7-11
Drive Speed (fast) - sec./25ft (7.6 m)	4.8-5.8
Elevated Drive Speed - sec./25ft (7.6 m)	34.5 - 37
Elevation Switch Height (drive speed slow)	90-96 in. (2.3 - 2.4 m)
Platform Lift Up Speed (platform empty)	25-29 seconds
Platform Lowering Speed (platform empty)	21-27 seconds
Max Operating Hydraulic Pressure	3,300 psi (234 bar)
Electrical System Voltage	12 volt
Ground Clearance	8 in (20.3 cm)

## SECTION 6 - GENERAL SPECIFICATIONS AND OPERATOR MAINTENANCE

### Dimensional Data

**Table 6-2. Dimensional Data**

Overall Height Stowed (rails up) Global: Sp. Order Machines w/Long Lev. Jacks: (Australia Only)	7.75 ft (2.4 m) 8 ft (2.45 m)
Platform Height (Plat. Stowed) Global: Sp. Order Machines w/Long Lev. Jacks: (Australia Only)	49.5 in (1.25 m) 54.5 in (1.38 m)
Platform dimensions (extension retracted)	5.5 ft X 8.5 ft (1.6 X 2.6 m)
Platform dimensions (extension extended)	5.5 ft X 12.5 ft (1.6 X 3.8 m)
Overall machine dimensions	5.75 ft X 8.75 ft (1.8 m X 2.7 m)

### Capacities

**Table 6-3. Capacities**

Fuel Tank	7.2 gal (27.2 L)
Hydraulic Tank	15 gal (56.8 L)

**Table 6-3. Capacities**

Engine Crankcase Gasoline Diesel	3.4 qt (3.25 L) 4.2 qt (4 L)
Coolant Gasoline Engine Diesel Engine	1.25 gal (4.7 L) 1.5 gal (5.7 L)

### Tires

**Table 6-4. Tire Specifications**

Size	26X12-15 Pneumatic	26X12-15 Foam Filled
Ply Rating	8	8
Inflation Pressure	55 psi (4 bar)	--
Wheel Nut Torque	105 ft lb (142 Nm)	

### Batteries

**Table 6-5. Engine Battery Specifications**

Voltage	12V
Cranking Performance	700 @ 0° F
Reserve Capacity	115 minutes @ 80° F

## SECTION 6 - GENERAL SPECIFICATIONS AND OPERATOR MAINTENANCE

### Engine

Table 6-6. Engine Specifications

Type	WG750-B Kubota Gasoline/LP	DF752-E2 Kubota Gasoline/LP (1)	D905-B Kubota Diesel	D1005 Kubota Diesel
Number of Cylinders	3	3	3	3
Displacement	45.2 in <sup>3</sup> (0.74 L)	45.2 in <sup>3</sup> (0.74 L)	54.8 in <sup>3</sup> (0.9 L)	61.08 in <sup>3</sup> (1.001 L)
Bore x Stroke	2.7 in X 2.7 in (68 mm X 68 mm)	2.7 in. x 2.7 in. (68mm x 68mm)	2.8 in X 2.9 in (72 mm X 73.6 mm)	2.99 in X 2.9 in (76 mm X 73.6 mm)
Low RPM High RPM	1500 rpm 3600 rpm	1500 rpm 3600 rpm	800 rpm 3800 rpm	800 rpm 3800 rpm
Fuel Type	Gasoline/LP Gas	Gasoline/LP Gas	Diesel	Diesel

**(1)** - JLG machines equipped with TIER 3 carbureted model engine: Kubota DF752-E2

The Altitude Compensation Kit on this TIER 3 engine is set up from the factory to EPA emission standards for altitudes below 2800 ft. (700m). Kits for operating at higher altitudes are available from Kubota.

If operating at higher altitudes without the proper kit installed, this engine will run with a rich fuel mixture and may therefore exhibit the following issues:

- *Excessive exhaust temperature: This may rapidly or immediately damage the catalyst (if equipped). Engine overheating may also occur.*
- *Excessive soot: This will rapidly deteriorate the engine oil, the valves, and the exhaust ports with carbon deposits. If enough soot is built up the catalyst (if equipped) may not function properly.*
- *Emissions: Kubota cannot guarantee emissions without the proper Altitude Compensation kit installed.*

## SECTION 6 - GENERAL SPECIFICATIONS AND OPERATOR MAINTENANCE

### ENGINE SPECIFICATIONS

4150548\_E

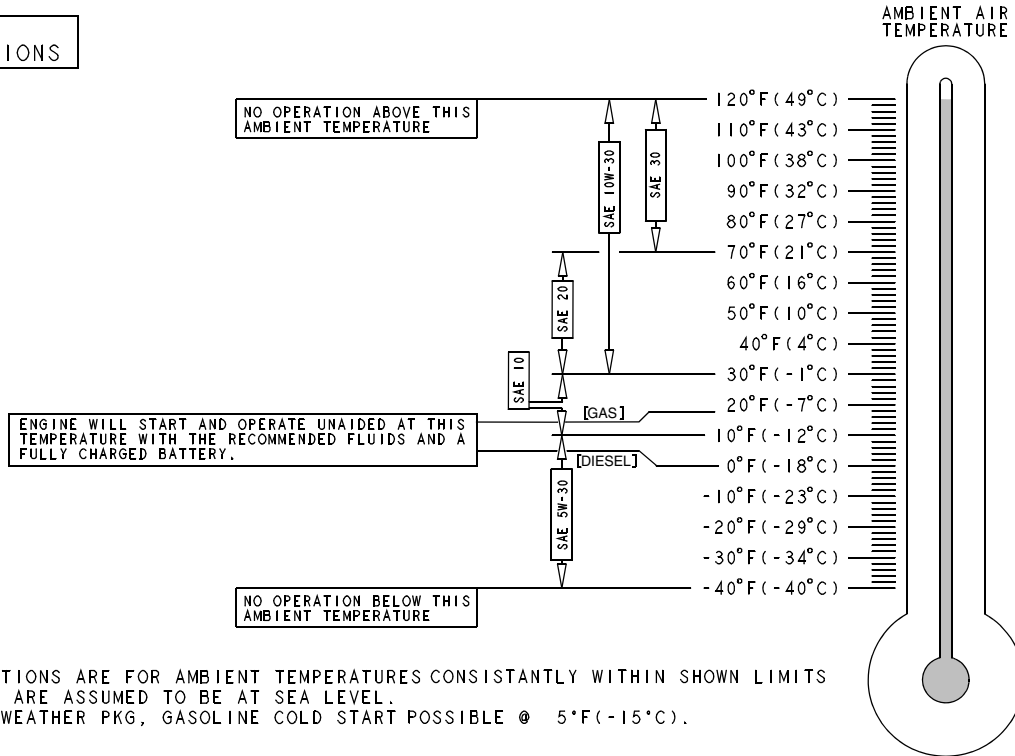

**NOTE:**

- 1) RECOMMENDATIONS ARE FOR AMBIENT TEMPERATURES CONSISTANTLY WITHIN SHOWN LIMITS
- 2) ALL VALUES ARE ASSUMED TO BE AT SEA LEVEL.
- 3) WITH COLD WEATHER PKG, GASOLINE COLD START POSSIBLE @ 5°F (-15°C).

**Figure 6-1. Engine Operating Temperature Specifications (Kubota)- Sheet 1 of 2**

# SECTION 6 - GENERAL SPECIFICATIONS AND OPERATOR MAINTENANCE

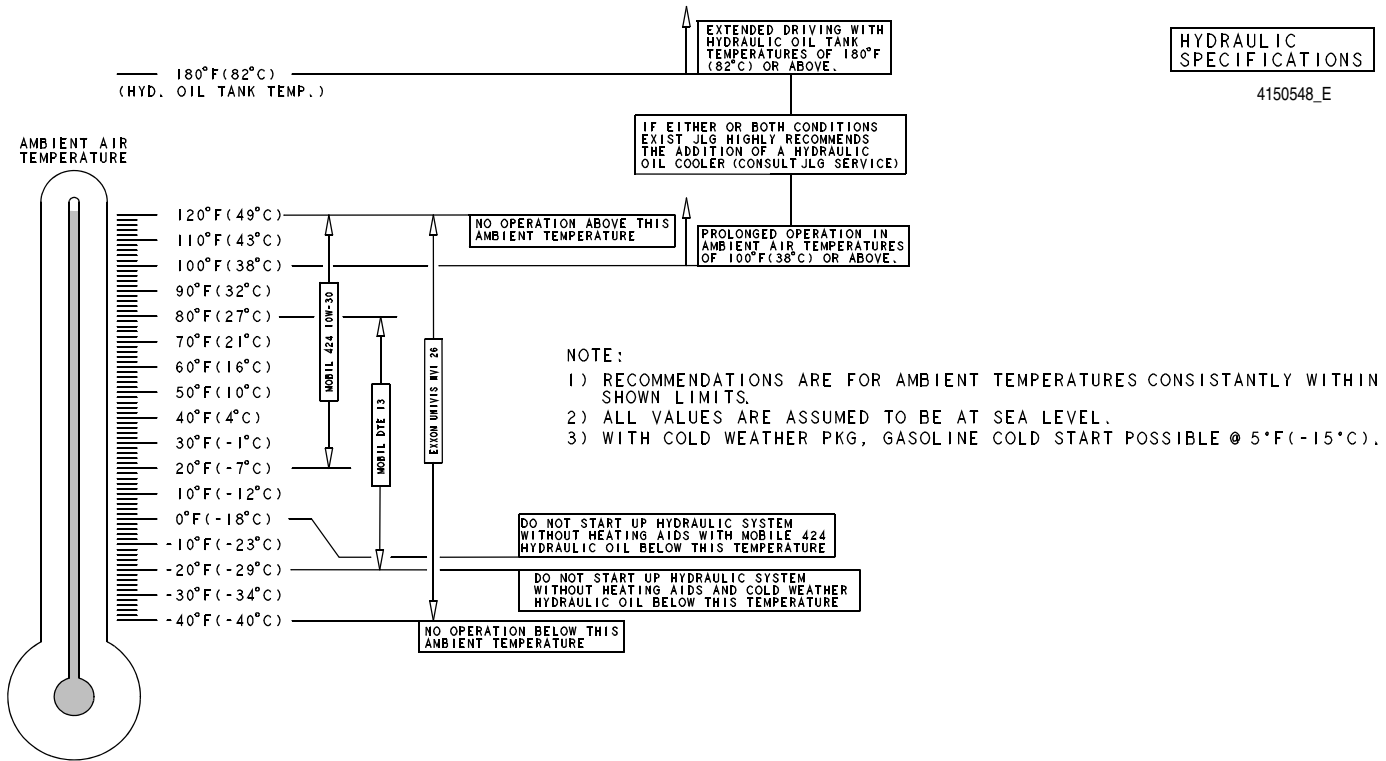

Figure 6-2. Engine Operating Temperature Specifications (Kubota)- Sheet 2 of 2



## SECTION 6 - GENERAL SPECIFICATIONS AND OPERATOR MAINTENANCE

### Lubrication

#### Hydraulic Oil

**Table 6-7. Hydraulic Oil**

HYDRAULIC SYSTEM OPERATING TEMPERATURE RANGE	SAE VISCOSITY GRADE
0° to +23° F (-18° to -5° C)	10W
0° to +210° F (-18° to +100° C)	10W-20, 10W-30
+50° to +210° F (+10° to +100° C)	20W-20

**NOTE:** Hydraulic oils must have anti-wear qualities at least to API Service Classification GL-3, and sufficient chemical stability for mobile hydraulic system service. JLG Industries recommends Mobilfluid 424 hydraulic oil, which has an SAE viscosity index of 152.

**NOTE:** When temperatures remain below -7° C (20° F), JLG Industries recommends the use of Mobil DTE13.

**NOTE:** Aside from JLG recommendations, it is not advisable to mix oils of different brands or types, as they may not contain the same required additives or be of comparable viscosities. If use of hydraulic oil other than Mobilfluid 424 is desired, contact JLG Industries for proper recommendations.

#### Lubrication Specifications

**Table 6-8. Lubrication Specifications**

KEY	SPECIFICATIONS
<b>MPG</b>	Multipurpose Grease having a minimum dripping point of 350° F. Excellent water resistance and adhesive qualities, and being of extreme pressure type. (Timken OK 40 pounds minimum.)
<b>EPGL</b>	Extreme Pressure Gear Lube (oil) meeting API service classification GL-5 or MIL-Spec MIL-L-2105.
<b>E0</b>	Engine (crankcase) Oil. Gas - API SF/SG class, MIL-L-2104. Diesel - API CC/CD class, MIL-L-2104B/MIL-L-2104C.
<b>HO</b>	Hydraulic Oil. API service classification GL-3, e.g. Mobil 424.

**6.3 OPERATOR MAINTENANCE**

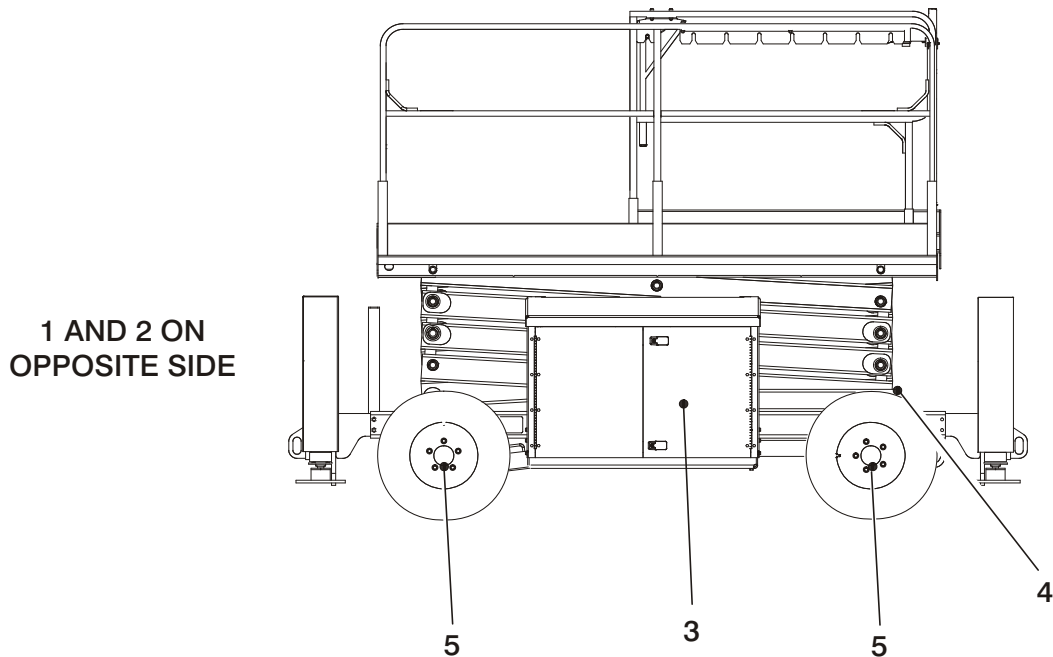

**Figure 6-3. Lubrication Diagram**

## SECTION 6 - GENERAL SPECIFICATIONS AND OPERATOR MAINTENANCE

### **WARNING**

**TO AVOID PERSONAL INJURY, USE SAFETY PROP FOR ALL MAINTENANCE REQUIRING PLATFORM TO BE ELEVATED.**

**NOTE:** *Be sure to lubricate like items on each side*

**NOTE:** *Recommended lubricating intervals are based on machine operations under normal conditions. For machines used in multi-shift operations and/or exposed to hostile environments or conditions, lubrication frequencies must be increased accordingly.*

*Operate hydraulic functions through one complete cycle before checking hydraulic oil level in tank. Oil should be visible in ADD sight window on hydraulic tank. If oil is not visible, add oil until oil is visible in both ADD and FULL sight windows on tank. Do not overfill tank.*

**NOTE:** *The following numbers correspond to those in Figure 6-3., Lubrication Diagram.*

**1. Hydraulic Oil**

Lube Point - Fill Level/Drain Plug

Lube - HO

Interval - Check oil every 10 hours of operation; change oil every 2 years or 1200 hours of operation.

**2. Hydraulic Filter Element**

Interval - Initial change 40 hours, every 250 hours of operation thereafter.

**3. Engine Compartment**

**a. Engine Oil Check/Fill**

Capacity - See Engine Manual

Lube - See Engine Manual

Interval - Check level daily; change per manufacturer's engine manual.

**b. Air Cleaner**

Lube Point - Filter Element

Interval - Check every 3 months or 150 hours; change every 6 months or 300 hours.

**c. Fuel Filter**

Lube Point - Filter Element

Interval - Clean every 3 months or 150 hours; change every 6 months or 300 hours.

**4. Sliding Wear Pads**

Lube Points - 8 Sliding Wear Pads

Lube - MPG

Interval - Every month or 50 hours.

**5. Drive Hub**

Lube Point - Fill Plug

Lube - EPGL

Interval - Every 2 years or 1200 hours

### 6.4 TIRES AND WHEELS

#### Tire Damage

For pneumatic tires, JLG Industries, Inc. recommends that when any cut, rip, or tear is discovered that exposes sidewall or tread area cords in the tire, measures must be taken to remove the JLG product from service immediately. Arrangements must be made for replacement of the tire or tire assembly.

For polyurethane foam filled tires, JLG Industries, Inc. recommends that when any of the following are discovered, measures must be taken to remove the JLG product from service immediately and arrangements must be made for replacement of the tire or tire assembly.

- a smooth, even cut through the cord plies which exceeds 7.5 cm (3 in) in total length
- any tears or rips (ragged edges) in the cord plies which exceeds 2.5 cm (1 in) in any direction
- any punctures which exceed 2.5cm in diameter
- any damage to the bead area cords of the tire

If a tire is damaged but is within the above noted criteria, the tire must be inspected on a daily basis to insure the damage has not propagated beyond the allowable criteria.

#### Tire Replacement

JLG recommends a replacement tire be the same size, ply and brand as originally installed on the machine. please refer to the JLG Parts Manual for the part number of the approved tires for a particular machine and model. If not using a JLG approved replacement tire, we recommend that replacement tires have the following characteristics:

- Equal or greater ply/load rating and size of original
- Tire tread contact width equal or greater than original
- Wheel diameter, width, and offset dimensions equal to the original.
- Approved for application by the tire manufacturer (Including inflation pressure and maximum tire load).

Unless specifically approved by JLG Industries Inc. do not replace a foam filled tire assembly with a pneumatic tire. When selecting and installing a replacement tire, ensure that all tires are inflated to the pressure recommended by JLG. Due to size variations between tire brands, both tires on the same axle should be the same.

### Wheel Replacement

The rims installed on each product model have been designed for stability requirements which consist of track width, tire pressure, and load capacity. Size changes such as rim width, center piece location, larger or smaller diameter, etc., without written factory recommendations, may result in an unsafe condition regarding stability.

### Wheel Installation

It is extremely important to apply and maintain proper wheel mounting torque.

#### **⚠ WARNING**

**WHEEL NUTS MUST BE INSTALLED AND MAINTAINED AT THE PROPER TORQUE TO PREVENT LOOSE WHEELS, BROKEN STUDS, AND POSSIBLE DANGEROUS SEPARATION OF WHEEL FROM THE AXLE. BE SURE TO USE ONLY THE NUTS MATCHED TO THE CONE ANGLE OF THE WHEEL.**

Tighten the lug nuts to the proper torque to prevent wheels from coming loose. Use a torque wrench to tighten the fasteners. If you do not have a torque wrench, tighten the fasteners with a lug wrench, then immediately have a service garage or dealer tighten the lug nuts to the proper torque. Over-tightening will result in breaking the studs or permanently deforming the

mounting stud holes in the wheels. The proper procedure for attaching wheels is as follows:

1. Start all nuts by hand to prevent cross threading. DO NOT use a lubricant on threads or nuts.
2. Tighten nuts in the following sequence:

#### 5 LUG PATTERN

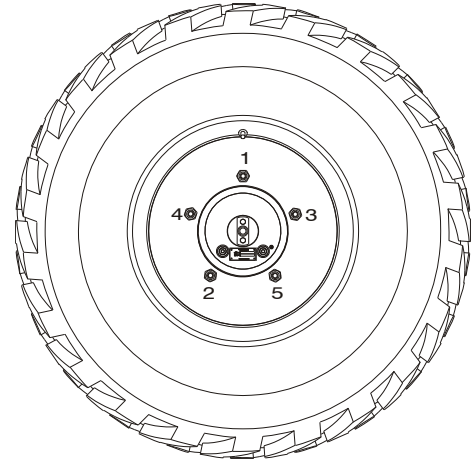

3. The tightening of the nuts should be done in stages. Using the recommended sequence, tighten the nuts per wheel torque chart following.

TORQUE SEQUENCE		
1st Stage	2nd Stage	3rd Stage
35 - 55 ft lbs (49 - 77 Nm)	65 - 80 ft lbs (91 - 112 Nm)	90 - 105 ft lbs (126 - 142 Nm)

4. Wheel nuts should be torqued after the first 50 hours of operation and after each wheel removal. Check torque every 3 months or 150 hours of operation.

### 6.5 SUPPLEMENTAL INFORMATION

The following information is provided in accordance with the requirements of the European Machinery Directive 2006/42/EC and is only applicable to CE machines.

For electric powered machines, the equivalent continuous A-Weighted sound pressure level at the work platform is less than 70dB(A).

For combustion engine powered machines, guaranteed Sound Power Level (LWA) per European Directive 2000/ 14/ EC (Noise Emission in the Environment by Equipment for Use Outdoors) based on test methods in accordance with Annex III, Part B, Method 1 and 0 of the directive, is 109 dB.

The vibration total value to which the hand-arm system is subjected does not exceed 2,5 m/s<sup>2</sup>. The highest root mean square value of weighted acceleration to which the whole body is subjected does not exceed 0,5 m/s<sup>2</sup>.

SECTION 7. INSPECTION AND REPAIR LOG

Table 7-1. Inspection and Repair Log

Date	Comments

**SECTION 7 - INSPECTION AND REPAIR LOG**

---

**Table 7-1. Inspection and Repair Log**

<b>Date</b>	<b>Comments</b>





An Oshkosh Corporation Company

# TRANSFER OF OWNERSHIP

## To Product Owner:

If you now own but **ARE NOT** the original purchaser of the product covered by this manual, we would like to know who you are. For the purpose of receiving safety-related bulletins, it is very important to keep JLG Industries, Inc. updated with the current ownership of all JLG products. JLG maintains owner information for each JLG product and uses this information in cases where owner notification is necessary.

Please use this form to provide JLG with updated information with regard to the current ownership of JLG products. Please return completed form to the JLG Product Safety & Reliability Department via facsimile or mail to address as specified below.

Thank You,  
Product Safety & Reliability Department  
*JLG Industries, Inc.*  
13224 Fountainhead Plaza  
Hagerstown, MD 21742  
USA  
Telephone: +1-717-485-6591  
Fax: +1-301-745-3713

**NOTE:** Leased or rented units should not be included on this form.

Mfg. Model: \_\_\_\_\_

Serial Number: \_\_\_\_\_

Previous Owner: \_\_\_\_\_

Address: \_\_\_\_\_

Country: \_\_\_\_\_ Telephone: (\_\_\_\_) \_\_\_\_\_

Date of Transfer: \_\_\_\_\_

Current Owner: \_\_\_\_\_

Address: \_\_\_\_\_

Country: \_\_\_\_\_ Telephone: (\_\_\_\_) \_\_\_\_\_

**Who in your organization should we notify?**

Name: \_\_\_\_\_

Title: \_\_\_\_\_



## **PROPOSITION 65 WARNING**

- **Battery posts, terminals and related accessories contain lead and lead compounds, chemicals known to the State of California to cause cancer and reproductive harm.**
- **Batteries also contain other chemicals known to the State of California to cause cancer.**
- **Wash hands after handling.**



An Oshkosh Corporation Company

Corporate Office  
JLG Industries, Inc.  
1 JLG Drive  
McConnellsburg PA. 17233-9533  
USA

(717) 485-5161

(717) 485-6417



3121219

## JLG Worldwide Locations

JLG Industries (Australia)  
P.O. Box 5119  
11 Bolwarra Road  
Port Macquarie  
N.S.W. 2444  
Australia

+61 2 65 811111

+61 2 65 810122

JLG Latino Americana Ltda.  
Rua Eng. Carlos Stevenson,  
80-Suite 71  
13092-310 Campinas-SP  
Brazil

+55 19 3295 0407

+55 19 3295 1025

JLG Industries (UK) Ltd  
Bentley House  
Bentley Avenue  
Middleton  
Greater Manchester  
M24 2GP - England

+44 (0)161 654 1000

+44 (0)161 654 1001

JLG France SAS  
Z.I. de Fauillet  
47400 Tonneins  
France

+33 (0)5 53 88 31 70

+33 (0)5 53 88 31 79

JLG Deutschland GmbH  
Max-Planck-Str. 21  
D - 27721 Ritterhude - Ihlpohl  
Germany

+49 (0)421 69 350 20

+49 (0)421 69 350 45

JLG Equipment Services Ltd.  
Rm 1107 Landmark North  
39 Lung Sum Avenue  
Sheung Shui N. T.  
Hong Kong

(852) 2639 5783

(852) 2639 5797

JLG Industries (Italia) s.r.l.  
Via Po. 22  
20010 Pregnana Milanese - MI  
Italy

+39 029 359 5210

+39 029 359 5845

Oshkosh - JLG Singapore T. E. P. Ltd.  
29 Tuas Ave 4  
Jurong Industrial Estate  
639379  
Singapore

+65-6591-9030

+65-6591-9031

Plataformas Elevadoras  
JLG Iberica, S.L.  
Trapadella, 2  
P.I. Castellbisbal Sur  
08755 Castellbisbal, Barcelona  
Spain

+34 93 772 4700

+34 93 771 1762

JLG Sverige AB  
Enkopingsvagen 150  
Box 704  
SE - 176 27 Jarfalla  
Sweden

+46 (0)850 659 500

+46 (0)850 659 534